

# Easy Cover Update

## REVISED INSTRUCTIONS

### How to Install the Aluminum Cross Arm and Connecting Arms

#### Parts you will need:

- Tarp (1)
- Cross arm (1)
- Lower swing arm (2)
- Upper swing arms (2)
- Swing arm castings (2)
- 4" tarp-centering springs (2)
- 1/4" eye bolts (2)
- 1/4" Nyloc nuts (4)
- 5/16" split lock washers (8)
- 5/16" hex bolts (4)
- ArmGuard Rubber Bumpers (2)
- Mild soap and water mixture (optional)

1. Refer to figure 1. Feed the cross arm through the pocket in the end of the tarp.

Figure 1

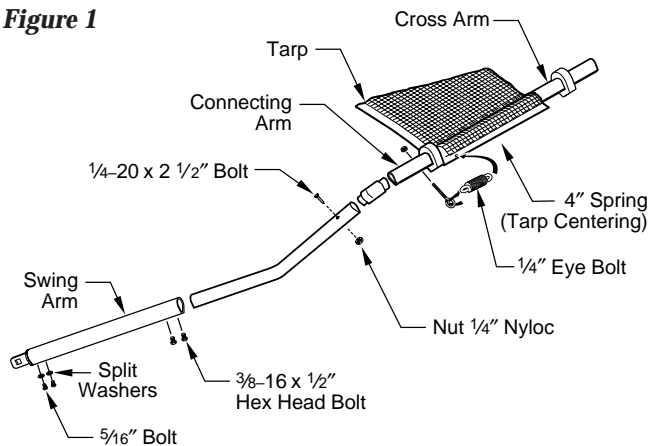

2. Insert castings into top of each upper arm (the short section of the bend). Make sure that the castings face opposite directions.
3. Drill through the arm and casting about 2" from where they join. Aero recommends drilling from top to bottom. This will position the bolt so that it does not rub against the truck body.  
**NOTE:** The casting and arm assembly can be drilled from side to side, but then there is a chance that the screw will rub against the truck body. You will need to place a washer on the bolt if you choose to do this. (Washer not provided.)
4. Insert the 1/4 x 2 1/2 bolt through the hole you just drilled. Drive a 1/4" locking nut on the screw to secure the casting in the arm.

5. Slide both upper arms onto the cross arm.
6. Raise the swing arm to the top of the tailgate and slide the ends of the upper arms into the lower arm.
7. Square the tarp and the rear cross bar with the top of the tail-gate.
8. Fasten the lower arms to the upper arms with 3/8" x 1/2" hex bolts.
9. Center the tarp from side to side on the rear cross bar.
10. Measure 3" from the edge of the tarp on both sides. Drill a 9/32" horizontal hole through the connecting arm and the cross arm. Do not drill through the tarp.
11. Before installing eyebolts and springs, slide rubber bumper over each end of cross arm and position inside of notch in tarp. Use a solution of mild soap and water for lubrication if necessary. Position bumpers to rest on tailgate as shown below.

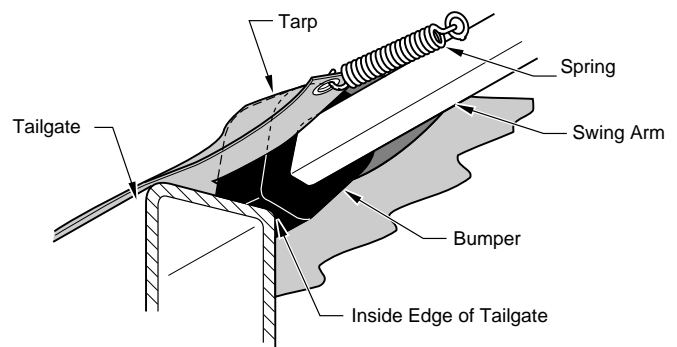

**CAUTION:** Use only mild soap and water mixture to install ArmGuard rubber bumpers. Mild soap and water evaporate quickly allowing the rubber bumper to clamp down on the cross arm. Use of common lubricants (oil, silicon, etc.) will prevent ArmGuard rubber bumpers from gripping the cross arm.

**NOTE:** ArmGuard rubber bumpers can be used on swing arms as well. ArmGuard rubber bumpers help prevent swing arm and dump body damage during motion.

12. Fasten the cross arms with eye bolts and nyloc nuts.
13. Attach the spring to the grommet in each corner of the tarp and to the eye bolt. Crimp the ends of the springs.

# You're Covered With Aero!

## WARRANTY

Aero products come with a one year warranty on all parts. It's another example of our ongoing commitment to customer satisfaction and quality.

## CUSTOMER SERVICE

1-800-535-9545

Our customer service technicians are trained to help you. Whether it's ordering, installation, or just general information on our products, you can count on expert advice from Aero.

© 2000 AERO INDUSTRIES, INC

0930-861620

11/01/00



INDIANAPOLIS  
3010 W. Morris Street  
P.O. Box 21066  
Indianapolis, IN 46221  
(800) 535-9545  
FAX (317) 244-1311

OMAHA  
I-80 & Highway 50 South  
P.O. Box 37598  
Omaha, NE 68137  
(800) 535-8552  
FAX (402) 895-6129

HAMBURG, PA  
2nd & Grand  
Hamburg, PA 19526  
(800) 535-3665  
FAX (215) 562-0340

PHOENIX, AZ  
3836 W. Buckeye Rd.  
Phoenix, AZ 85009  
(888) 224-8277  
FAX (602) 233-2929

BURLINGTON, ONTARIO  
AERO-KIT INDUSTRIES  
3474 Mainway Drive  
Burlington, Ontario  
L7M 1A8  
(905) 335-2012  
FAX (905) 335-8499