

# Aluminum Easy Pull

V2.0  
Aluminum Easy Pull

Installation, Maintenance,  
and Safety Instructions

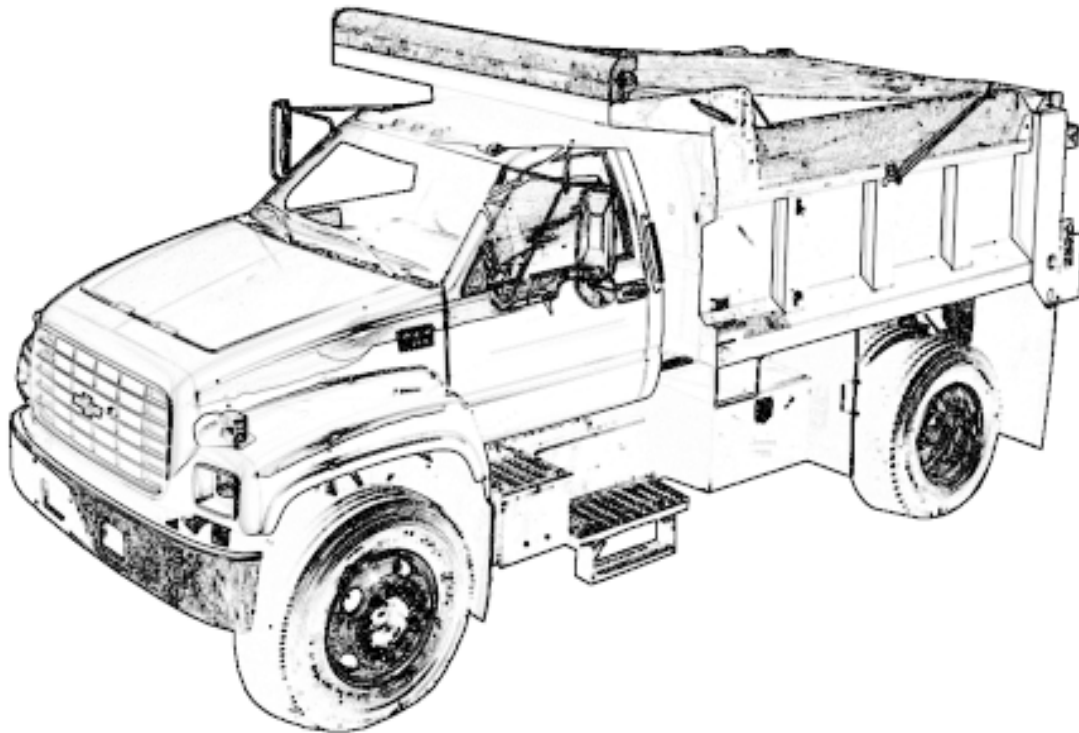

Attention Dealers:  
Please give this manual to  
the customer when the  
product is delivered.

Indianapolis, IN • Omaha, NE • Hamburg, PA • Phoenix, AZ • Burlington, Ontario (800) 535-9545

 **Aero**  
Industries, Inc.  
WE GO THE DISTANCE

# Aluminum Easy Pull

**Important:** This manual explains how to install, operate, and maintain the Easy Pull. Before installing or operating the Easy Pull, read the entire manual.

Three kinds of special explanations will appear throughout the manual. These are Warning, Caution, and Note. Be sure to read and follow them.

**Warning:** Possible danger to the operator or a bystander. The operator or bystander could be injured if you ignore this information.

**CAUTION:** Risk to the product. If you ignore this information, the Easy Pull or the truck could be damaged.

**Note:** Contains additional information about a feature or step critical to the operation of the cover.

## STEP 1

### Installing the Easy Pull Tarp Housing Assembly

*Parts you will need:*

*Tarp housing assembly*

**Note:** For ease of installation, the Easy Pull system comes with steel or aluminum mounting strips bolted to the bottom of the tarp housing.

1. Place the tarp housing assembly on the dump body so that it sits squarely with the dump body

**CAUTION:** Welding sparks can cause serious damage to the tarp. Take extreme care in shielding the tarp during all welding operations. Also, take care not to burn the tarp housing assembly.

2. Tack weld the mounting strips to the dump body enough to give the tarping system a trial run.
3. Pull the Easy Pull tarp to the back of the dump body. Check to make sure tarp is tracking squarely all the way to the back of the dump body. If it is not tracking squarely, you must re-align and re-tack the tarp housing assembly before proceeding to the next step.
4. Once you are sure the tarp housing assembly is correctly positioned, proceed with the final welding.

5. Weld the mounting strip three places across the front of the housing approximately 6" in from each end and directly in the center using 5" - 6" welds. (See Figure 1)

**Figure 1**

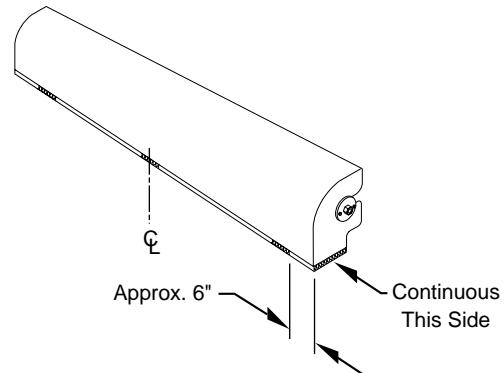

6. Weld the full length of the side mounting strips on the outside. (Refer to Figure 1)

## STEP 2

### Installing the Rear Hinge Ramps and Lock Brackets

*Parts you will need:*

*Lock brackets (2)*

*Hinge ramps (2)*

*5/16" x 1" self tapping bolts (4)*

*3/8" x 1 1/2" self tapping bolts (4)*

1. Measure down 8" from the top of the tailgate at the rear of the body. This is the location where you will mount the lock brackets. (See Figure 2)

# Aluminum Easy Pull

Figure 2

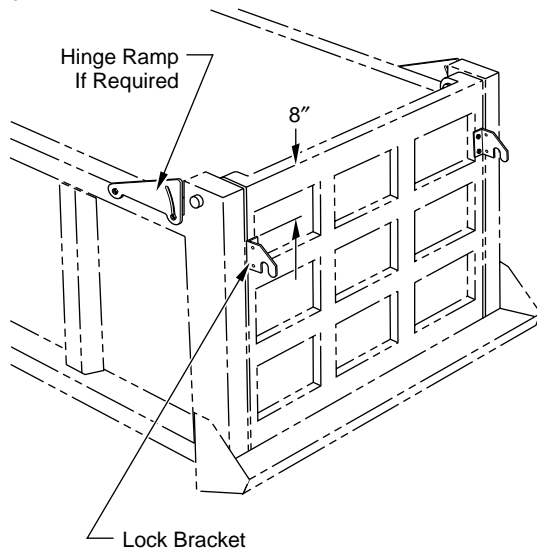

2. The brackets should be mounted on either the sides or rear face of the dump door. This will enable the load to be dumped without uncovering the load.
3. Place the top edge of the lock brackets at the 8" point and mark the location of the holes to be used. Drill  $1\frac{1}{32}$ " holes at these locations and attach the brackets with the  $\frac{3}{8}$ " x  $1\frac{1}{2}$ " self tapping bolts.

**Note:** Make sure that the lock brackets are wider than the tarp width so the roller brackets (plastic tube) will fit into the notch.

4. If the body has rear hinge blocks which extend higher than the top rail, the hinge ramps must be used to allow the rear pull tube to be pulled over the hinges. If the rear hinges do not extend over the top, proceed to Step 3.
5. The hinge ramps must be mounted on the outside of the top rail.
6. Place the hinge ramps directly in front of the hinge and mark the location of the hole on the small end of the ramp. Drill a  $\frac{9}{32}$ " hole and fasten with a  $\frac{5}{16}$ " x 1" self tapping bolt (do not tighten). Swing the hinge ramp up or down for desired height and mark a hole using the slotted hole of the ramp as a guide. Drill a  $\frac{9}{32}$ " hole at this location. Fasten with a  $\frac{5}{16}$ " x 1" self tapping bolt. Tighten all bolts completely.

## STEP 3

### Installing the Rope Hooks

Parts you will need:

Rope hooks (4)

$\frac{1}{4}$ " x 1" self tapping bolts (8)

1. With the tarp in the open position, bring the end of the rope over the side. Locate 2 rope hooks horizontally where convenient, approximately 36" apart. Mark the location of the holes using the holes in the rope hook as a guide and drill  $\frac{7}{32}$ " holes at these locations. Fasten with  $\frac{1}{4}$ " x 1" self tapping screws. Wrap the rope between the two hooks when the tarp is in the open position and tie off to secure. (See Figure 3)
2. Pull the tarp over the rear of the body and allow the pull tube rollers to lock into the slots in the rear lock brackets. The rope can either be unsnapped and removed or wrapped on tarp hooks as on the front of the body. If you desire to use the rope hooks on the rear, repeat the instructions used for mounting the front rope hooks.

Figure 3

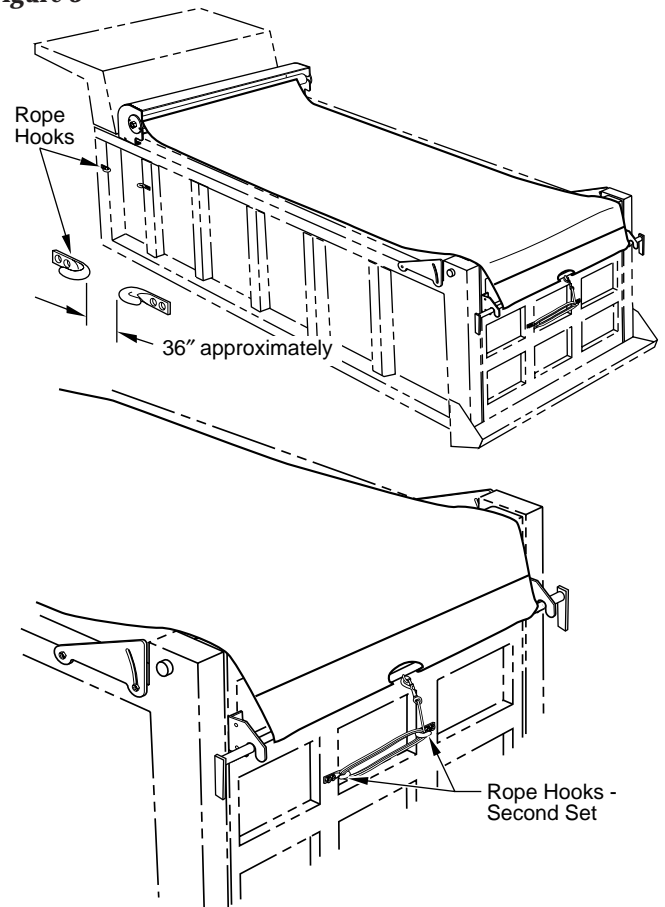

# Aluminum Easy Pull

## STEP 4

### Adjusting Spring Tension

Tools you will need:

$\frac{1}{8}$ " Allen wrench

$\frac{7}{8}$ " open end wrench

**CAUTION:** The Easy Pull Assembly comes pre-loaded from the factory. The shaft is under spring tension. Maintain a firm grasp on the wrench during the following operation.

Figure 4

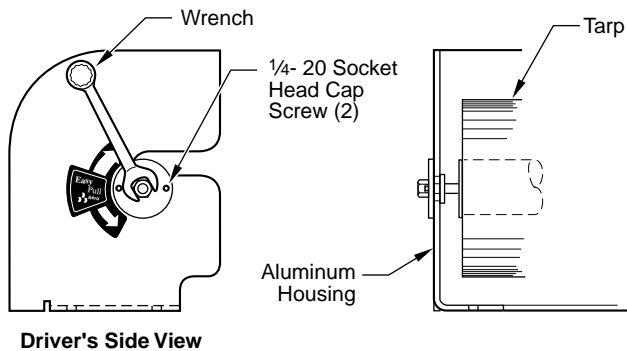

1. Secure the  $\frac{7}{8}$ " wrench on the adjustment nut. Using a  $\frac{1}{8}$ " Allen wrench loosen the  $\frac{1}{4}$ " socket head cap screws until they lose contact with the plate.
2. To add more spring tension, when facing the shaft, turn the wrench clockwise.
3. To lessen the spring tension, when facing the shaft, turn the wrench counter-clockwise.
4. You may have to turn the shaft one to two full revolutions to achieve the tension you require.
5. When proper tension is achieved, re-align holes in aluminum collar to holes in plate. Insert  $\frac{1}{4}$ -20 socket head cap screws and lock washers and barely tighten.
6. After you have slightly tightened the socket head cap screws, use the pull rope to pull the tarp all the way out. Then, holding onto the pull rope, allow the tarp to retract slowly into the Easy Pull Tarp Housing.

**Note: IMPORTANT!** Do not allow the tarp to "snap" back into the Easy Pull Tarp Housing.

7. If the spring tension is adequate to pull the tarp into the housing, go back and firmly tighten socket head cap screws. If the spring requires additional adjustment, repeat steps 1 through 7.

**Note:** Once your Easy Pull unit has 30 to 40 complete cycles. It may become necessary to re-adjust the spring tension. This is part of the natural process of breaking in a spring to a set condition. Once the spring has been broken in, no further adjustment will be required. **Over tightening the spring will cause permanent damage!**

## STEP 5

### Installing Tie-Down System (Optional)

Parts you will need:

Rope hooks (12)

$\frac{1}{4}$ " x 1" self tapping bolts (24)

1. See Figure 5. Pull the tarp out so that it covers the dump body. Fold the flaps over the side. Straps with D-rings should be hanging freely.

**Note:** When locating rope hooks, it is recommended they be located as low on the dump body as possible, and all at the same height. This will allow the system to work more effectively.

Figure 5

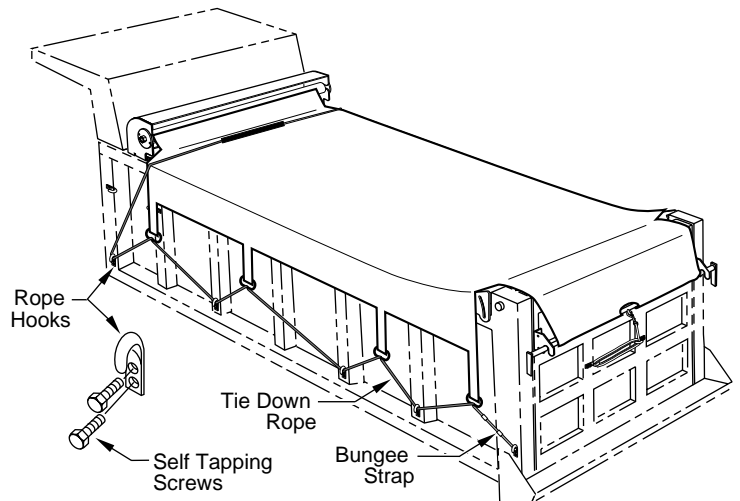

# Aluminum Easy Pull

- The rope hook located closest to the front of the dump body should be the first to be installed. It should be installed in the vertical position and as close to the front of the dump body as possible. It is important that this rope hook be positioned in front of the tarp strap. The farther forward it is located the more effectively it will function. Once the first rope hook is located, mark the location of the holes to be drilled using the rope hook as a guide. Drill two  $\frac{7}{32}$ " holes at these locations. Fasten the rope hooks to the dump body using the  $\frac{1}{4}$ " x 1" self tapping screws.
- The remaining rope hooks must be positioned in-between the remaining tarp straps. Once the remaining rope hooks are located, mark the location of the holes to be drilled using the rope hooks as guides. Drill two  $\frac{7}{32}$ " holes at these locations. Fasten the rope hooks to the dump body using the  $\frac{1}{4}$ " x 1" self tapping screws.
- The last rope hook should be located as close to the end of the dump body as possible. It is important that this rope hook be positioned behind the last tarp strap. The farther back it is located the more effectively it will function. Once the rear rope hook is located, mark the location of the holes to be drilled using the rope hook as a guide. Drill two  $\frac{7}{32}$ " holes at these locations. Fasten the rope hooks to the dump body using the  $\frac{1}{4}$ " x 1" self tapping screws.
- Once all the tarp hooks have been installed, lace the tie-down rope through all rope hooks. Standing at the rear of the dump body, pull all the slack out of the tie-down rope.
- Hook one end of the bungee strap to the rear rope hook. Tie the end of the tie-down rope to the other end of the bungee with a square knot. Make sure that the bungee strap is stretched with enough tension to hold the tarp in place in windy conditions.
- Once you have completed one side of the dump body, repeat operations 2 through 6 to complete the other side.

## STEP 6

### Installing Bottom Support Brackets (Optional)

#### Parts you will need:

- Bottom support brackets (2)
- $\frac{5}{16}$ " -18 x 1" hex head screws (8)
- $\frac{5}{16}$ " -18 hex nuts (8)
- $\frac{5}{16}$ " flat washers (12)

#### Tools you will need:

- $\frac{11}{32}$ " drill bit and drill

- See Figure 6. Install both bottom support brackets onto the bottom of the tarp housing assembly. Place the tarp housing assembly on the dump body so that it sits squarely. Using the holes in the support brackets as a guide, mark the location of the holes on the dump body.

Figure 6

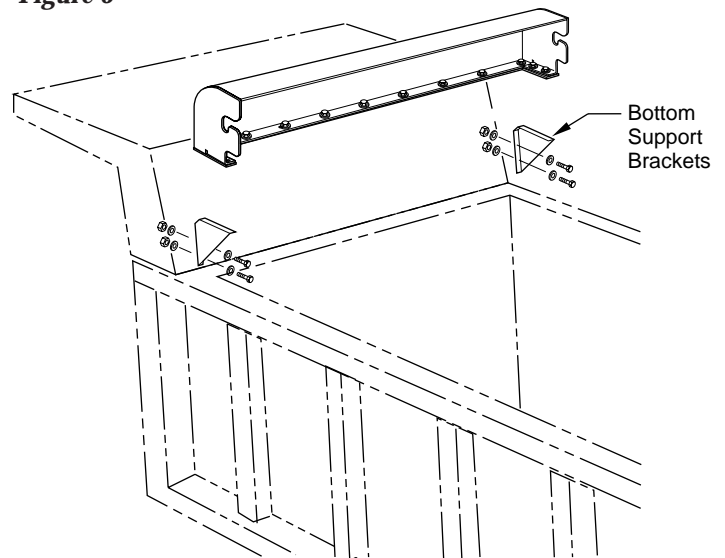

- Using an  $\frac{11}{32}$ " drill bit, drill the marked holes in the dump body.
- Weld the full length of the tarp housing mounting strips to the bracket on each side.

# Aluminum Easy Pull

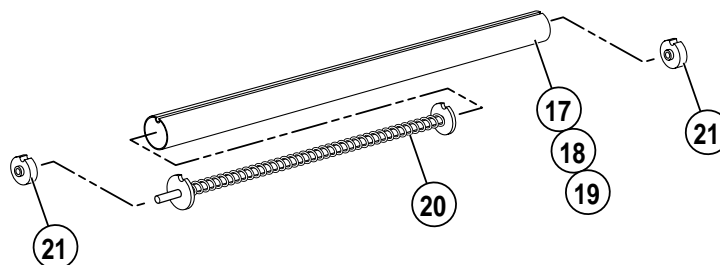
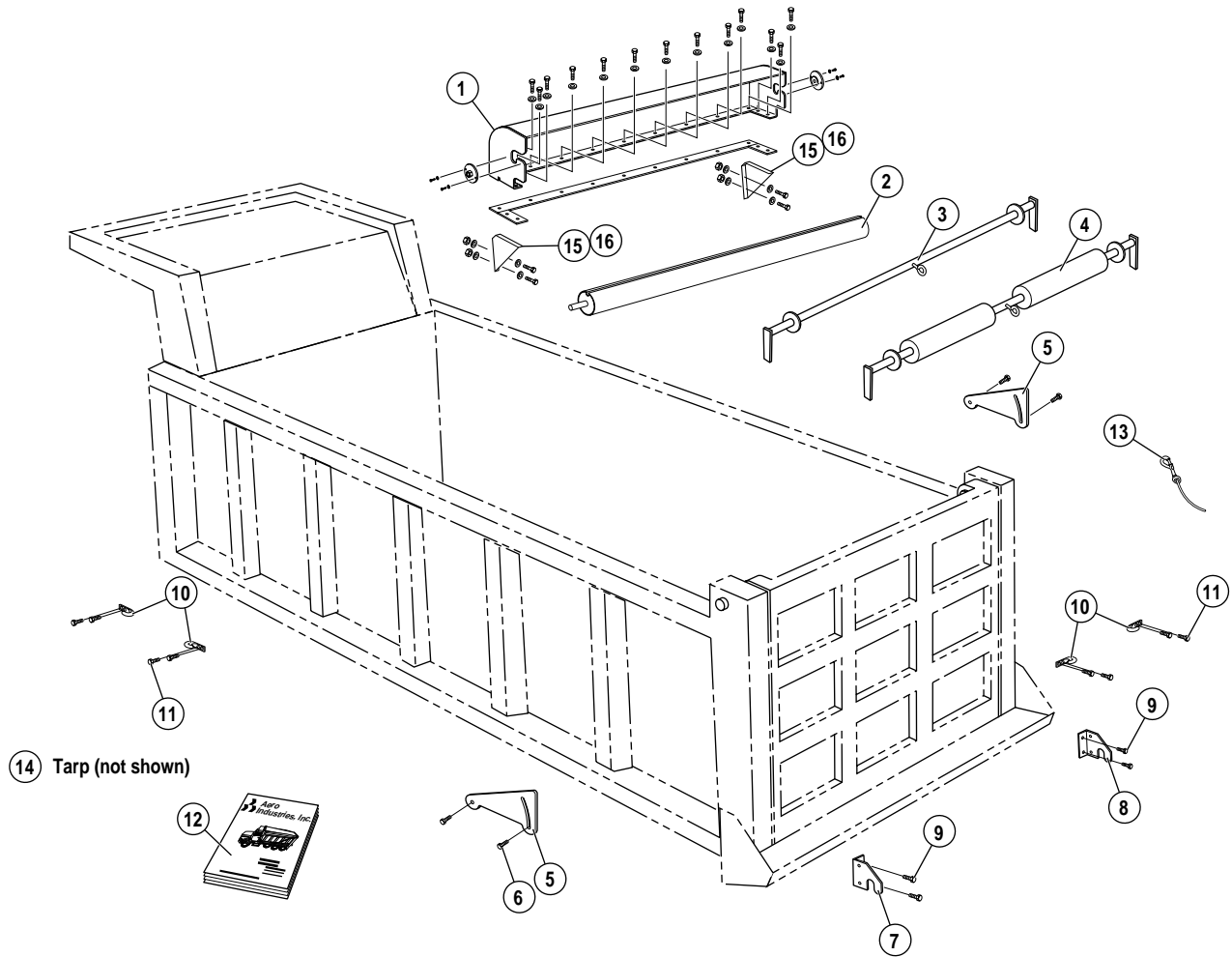

# Aluminum Easy Pull

No.	Part No.	Description	Qty.	No.	Part No.	Description	Qty.
1	0321-969011	92"-6" Tarp Housing Assembly	1	7	0321-861111	Lock Plate Rear D.S.	1
	0321-969012	96"-6" Tarp Housing Assembly	1	8	0321-861112	Lock Plate Rear P.S.	1
	0321-969013	102"-6" Tarp Housing Assembly	1	9	0825-650620	Bolt HWH 3/4" x 1 1/2" Self Tapping	4
	0321-969008	92"-9" Tarp Housing Assembly	1	10	0730-612360	Rope "J" Tarp Hook	4
	0321-969009	96"-9" Tarp Housing Assembly	1	11	0825-670450	Bolt HWH 1/4" x 1" Self Tapping	8
	0321-969010	102"-9" Tarp Housing Assembly	1	12	0930-861903	Installation Instructions Easy Pull	1
2	0321-968008	92" Roll Tube Assembly	1	13	0321-961115	Pull Rope Assembly	1
	0321-968006	96" Roll Tube Assembly	1	14		Easy Pull Tarp (not shown)	1
	0321-968009	102" Roll Tube Assembly	1	15	0321-963001	*Bottom Support Bracket Assembly 6" P.S.	1
3	0321-967008	92" Pull Bar Assembly	1		0321-963002	*Bottom Support Bracket Assembly 6" D.S.	1
	0321-967006	96" Pull Bar Assembly	1	16	0321-963003	*Bottom Support Bracket Assembly 9" P.S.	1
	0321-967009	102" Pull Bar Assembly	1		0321-963004	*Bottom Support Bracket Assembly 9" D.S.	1
4	0321-966004	92" Pull Bar Assembly with Heap Hopper	1	17	0321-868001	92" Roll Tube	1
	0321-966005	96" Pull Bar Assembly with Heap Hopper	1	18	0321-868002	96" Roll Tube	1
	0321-966007	103" Pull Bar Assembly with Heap Hopper	1	19	0321-868003	102" Roll Tube	1
	0321-961116	Hardware Package		20	0321-961126	Spring Assembly	1
5	0321-861113	Ramp Hinge Block	2	21	0321-961110	Casting Assembly	2
6	0810-650510	Bolt HWH 5/16" x 1" Self Tapping	4				

*\*Optional*

# You're Covered With Aero!

## WARRANTY

Aero products come with a one year warranty on all parts. It's another example of our ongoing commitment to customer satisfaction and quality.

## CUSTOMER SERVICE

1-800-535-9545

Our customer service technicians are trained to help you. Whether it's ordering, installation, or just general information on our products, you can count on expert advice from Aero.

© 2000 AERO INDUSTRIES, INC  
0930-861903  
5/03/00



INDIANAPOLIS  
3010 W. Morris Street  
P.O. Box 21066  
Indianapolis, IN 46221  
(800) 535-9545  
FAX (317) 244-1311

OMAHA  
I-80 & Highway 50 South  
P.O. Box 37598  
Omaha, NE 68137  
(800) 535-8552  
FAX (402) 895-6129

HAMBURG, PA  
2nd & Grand  
Hamburg, PA 19526  
(800) 535-3665  
FAX (215) 562-0340

PHOENIX, AZ  
3836 W. Buckeye Rd.  
Phoenix, AZ 85009  
(888) 224-8277  
FAX (602) 233-2929

BURLINGTON, ONTARIO  
AERO-KIT INDUSTRIES  
3474 Mainway Drive  
Burlington, Ontario  
L7M 1A8  
(905) 335-2012  
FAX (905) 335-8499