

Easy Pull

V1.0
Easy Pull

Installation, Maintenance,
and Safety Instructions

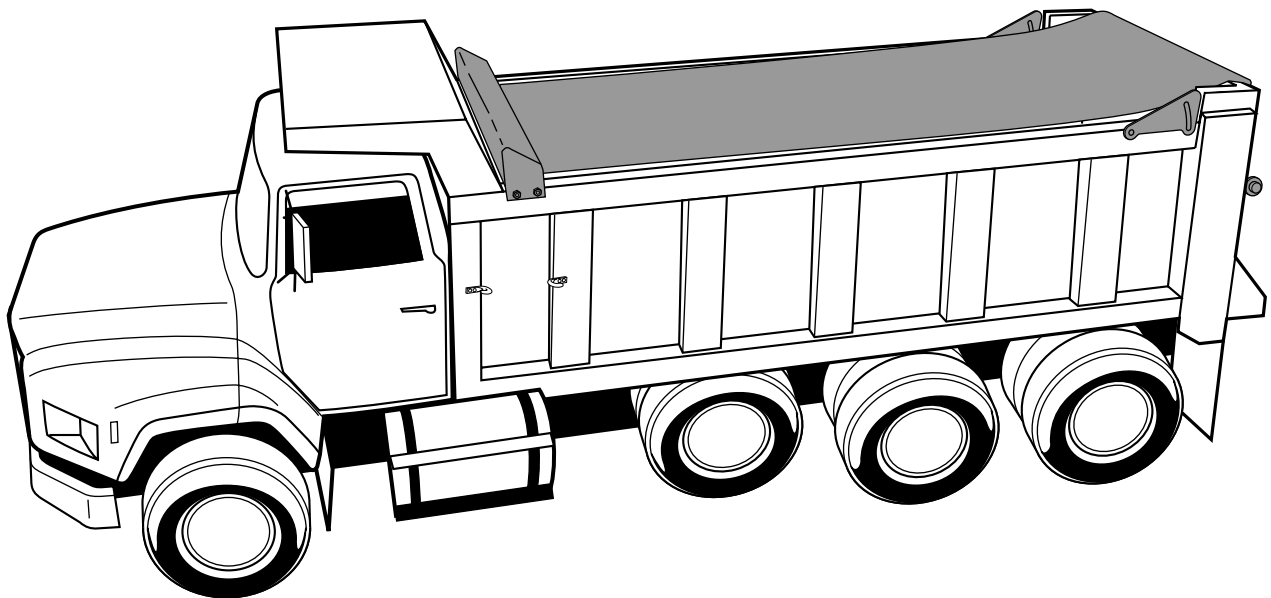

Attention Dealers:
Please give this manual to
the customer when the
product is delivered.

Indianapolis, IN • Omaha, NE • Hamburg, PA • Phoenix, AZ • Burlington, Ontario (800) 535-9545

 **Aero**
Industries, Inc.
WE GO THE DISTANCE

Important: This manual explains how to install, operate, and maintain the Easy Pull. Before installing or operating the Easy Pull, read the entire manual.

Three kinds of special explanations will appear throughout the manual. These are Warning, Caution, and Note. Be sure to read and follow them.

⚠ Warning: Possible danger to the operator or a bystander. The operator or bystander could be injured if you ignore this information.

CAUTION: Risk to the product. If you ignore this information, the Easy Pull or the truck could be damaged.

Note: Contains additional information about a feature or step critical to the operation of the cover.

STEP 1

Adjusting the Tarp Housing

Parts you will need:

Tarp housing assembly (1)

Note: If you have purchased one of the pre-assembled tarp housings, proceed to install the tarp housing, as described in Step 5.

1. See figure 1. Choose the location on the dump body where the tarp housing will be mounted and measure the outside width dimension.

Figure 1

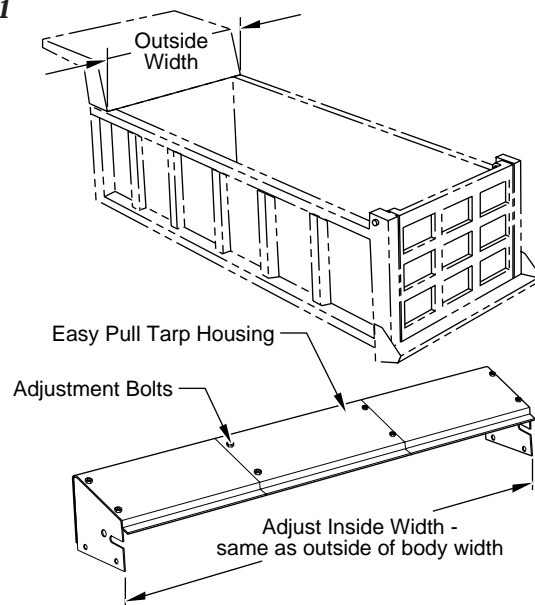

2. Loosen the adjustment bolts in the center section of the tarp housing on both ends and adjust the inside width of the end plates to match the outside width of the mounting location.
3. Tighten the adjustment bolts.

Note: If you have purchased the optional adjustable mounting bracket kit, see Step 8 assembly.

STEP 2

Assembling the Roller Tube

Parts you will need:

Roller tube 3 1/4" (1)

Spring assembly (1)

Aluminum end casting (1)

1. See figure 2. Cut the roller tube 7/8" shorter than the distance between the inside of the tarp housing end plates.

Figure 2

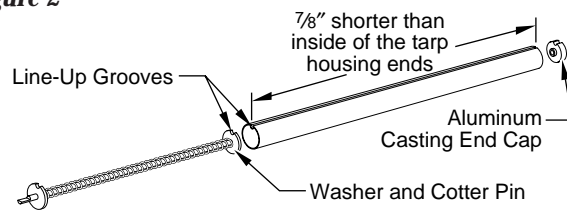

2. Insert the pre-assembled spring assembly in the roller tube, lining up the grooves in the aluminum casting with the grooves in the tube.

Note: Aero Industries recommends rolling the tarp off the bottom of the roller tube. If you want the tarp to roll off the bottom, insert the spring assembly into the driver's side of the tube. If you want the tarp to roll over the top, insert the spring assembly into the passenger side of the tube.

3. Insert the loose aluminum casting into the opposite end of the roller tube.

STEP 3

Assembling the Roll-Up Tube Into Tarp Housing

Parts you will need:

Tarp housing (1)

Roll-up tube assembly (1)

Plastic washer (2)

1/2" x 2 1/2" clevis pin (1)

1. See figure 3. Install a plastic washer onto the shaft protruding from the spring assembly end of the roller tube. Insert the shaft through the tarp housing end plate and lock collar. Adjust the shaft on the spring assembly of the roller tube so that the shaft protrudes 1" out beyond the lock collar. Do not tighten the set screw in this end at this time. Position the other end of the roller tube up to the other end of the tarp housing. Insert the 1/2" clevis pin through the lock collar, end plate, plastic washer, and into the aluminum casting on the roller tube. Tighten set screw in this end only.

Figure 3

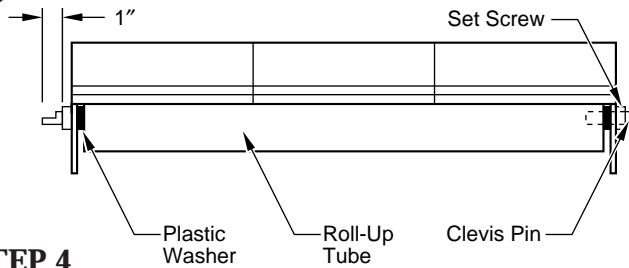

STEP 4

Fastening the Tarp Onto the Roller Tube

Parts you will need:

Tarp housing/roll-up tube assembly (1)

Rear pull tube (1)

Rear roller assembly (2)

Tarp (1)

#10 x 3/4" screw (2)

1/4" x 1 1/2" eyebolt (1)

1/4" lock nut (1)

Pull rope (1)

1/4" x 1 1/4" spring pin (2)

Note: The tarp should measure 2" narrower than the inside width and 12" longer than the length of the dump body.

1. See figure 4. Clamp the tarp housing assembly onto a table or elevated surface. Lay the tarp out below the housing and insert the front of the tarp (plastic extrusion) into the groove of the roll-up tube.

Figure 4

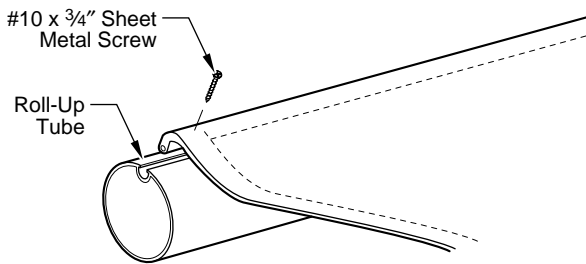

2. Center the tarp on the roller tube and drill a 9/64" hole through the plastic extrusion, and into the roller tube in each end. Secure the tarp to the tube with the #10 x 3/4" sheet metal screws.
3. See figure 5. Measure the width of the tarp at the rear (pocket end). Cut the rear pull tube 1 1/4" shorter than that measurement. Insert a roller assembly into one end of the tube. Butt the inside lock collar up against the tube and drill a 1/4" hole completely through the tube and bar. Secure with a 1/4" x 1 1/4" spring pin. Insert the rear aluminum pull tube in the rear pocket of the tarp. Insert the other roller assembly in the end of the pull tube, butting the shaft of the collar up against the tube. Drill and secure as stated above.

Figure 5

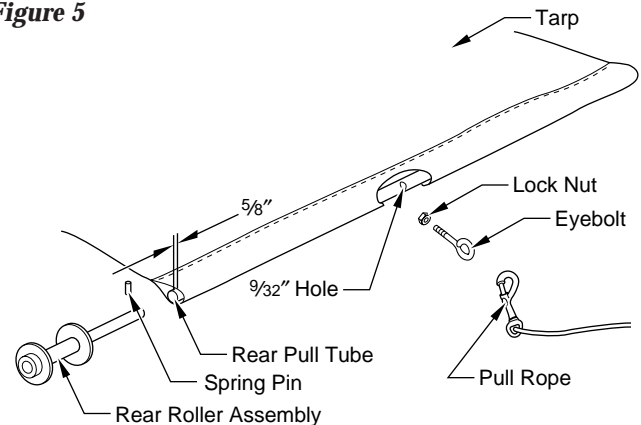

4. Find the center of the rear pull tube (cut-out on tarp) and drill a 9/32" hole completely through the tube. Install the eyebolt and lock nut with the eyebolt protruding out of the tarp cut-out.
5. Snap the pull rope onto the eyebolt.

CAUTION: Maintain a firm grasp on vise grips during the following operation.

6. See figure 6. Clamp a pair of vise grips securely onto the shaft protruding from the tarp housing. Facing the shaft, turn the vise grips clockwise. This will preload the spring and wind the tarp around the roller tube. You may have to turn the shaft several times before the tarp starts to wind on the roller tube. Wind the shaft until the rear pull tube assembly is resting against the tarp housing. After the tarp is fully wound and while holding the vise grips firmly so the shaft doesn't rotate, have a second person pull the tarp completely off of the roller tube and then let it re-roll onto the roller tube while holding back with light pressure. Do not let the tarp roll up freely; it may damage the rear pull bar. If more spring tension is required to wind tarp onto roll tube, turn the vise grips one or two more turns and re-test. When the proper spring tension is achieved, tighten the set screw in the lock collar onto the flat surface of the shaft. The set screw must be on the flat surface of the shaft to prevent shaft from unwinding the spring tension.

Figure 6

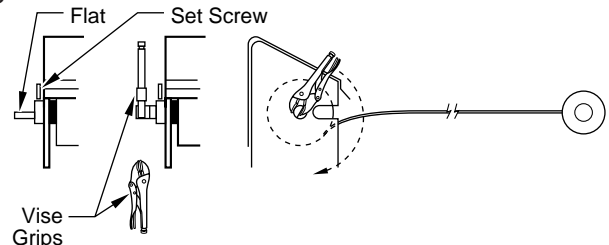

STEP 5

Installing the Tarp Housing

Parts you will need:

- Tarp housing/tarp assembly (1)*
- 5/16" x 1" hex bolt (4)*
- 5/16" flat washer (8)*
- 5/16" lock washer (4)*
- 5/16" hex nut (4)*

1. See figure 7. Lift the tarp housing into position. The bottom of the end plates will be 2" below the top of the rail. If more clearance is desired, the housing can be raised 1". Clamp the housing into position, making sure the assembly is vertically level. Using the holes in the mounting plates as a guide, drill $1\frac{1}{32}$ " holes and fasten with the $\frac{5}{16}$ " x 1" bolts, washers, and nuts provided.

Note: For some installations, the 1" bolts supplied may not be long enough. If this is the case, the installer must furnish the appropriate hardware.

Figure 7

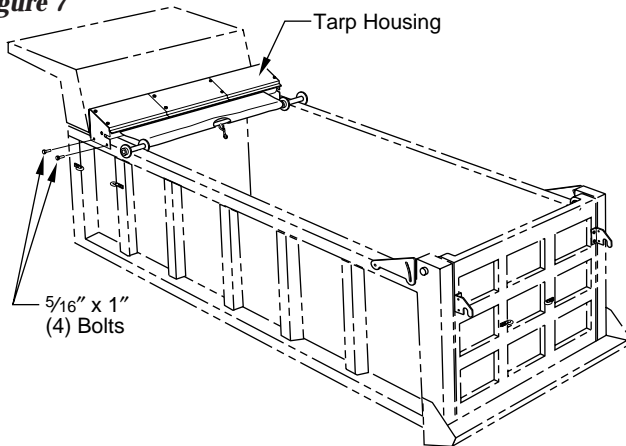

STEP 6

Installing the Rear Hinge Ramps and Lock Brackets

Parts you will need:

- Lock brackets (2)*
- Hinge ramps (2)*
- 5/16" x 1" self tapping bolts (4)*
- 3/8" x 1 1/2" self tapping bolts (4)*

1. See figure 8. Measure down 8" from the top of the tailgate at the rear of the body. This is the location where you will mount the lock brackets.

Figure 8

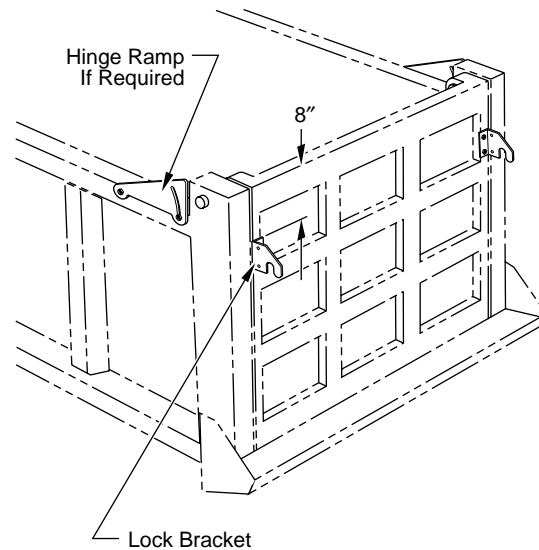

2. The brackets should be mounted on either the sides or rear face of the dump door. This will enable the load to be dumped without uncovering the load.
3. Place the top edge of the lock brackets at the 8" point and mark the location of the holes to be used. Drill $1\frac{1}{32}$ " holes at these locations and attach the brackets with the $\frac{3}{8}$ " x $1\frac{1}{2}$ " self tapping bolts.

Note: Make sure that the lock brackets are wider than the tarp width so the roller brackets (plastic tube) will fit into the notch.

4. If the body has rear hinge blocks which extend higher than the top rail, the hinge ramps must be used to allow the rear pull tube to be pulled over the hinges. If the rear hinges do not extend over the top, proceed to Step 7.
5. The hinge ramps must be mounted on the outside of the top rail.
6. Place the hinge ramps directly in front of the hinge and mark the location of the hole on the small end of the ramp. Drill a $\frac{9}{32}$ " hole and fasten with a $\frac{5}{16}$ " x 1" self tapping bolt (do not tighten). Swing the hinge ramp up or down for desired height and mark a hole using the slotted hole of the ramp as a guide. Drill a $\frac{9}{32}$ " hole at this location. Fasten with a $\frac{5}{16}$ " x 1" self tapping bolt. Tighten all bolts completely.

STEP 7

Installing the Rope Hooks

Parts you will need:

Rope hooks (4)

$\frac{1}{4}$ " x 1" self tapping bolts (8)

1. See figure 9. With the tarp in the open position, bring the end of the rope over the side. Locate 2 rope hooks horizontally where convenient, approximately 36" apart. Mark the location of the holes using the holes in the rope hook as a guide and drill $\frac{7}{32}$ " holes at these locations. Fasten with $\frac{1}{4}$ " x 1" self tapping screws. Wrap the rope between the two hooks when the tarp is in the open position and tie off to secure.
2. Pull the tarp over the rear of the body and allow the pull tube rollers to lock into the slots in the rear lock brackets. The rope can either be unsnapped and removed or wrapped on tarp hooks as on the front of the body. If you desire to use the rope hooks on the rear, repeat the instructions used for mounting the front rope hooks.

Figure 9

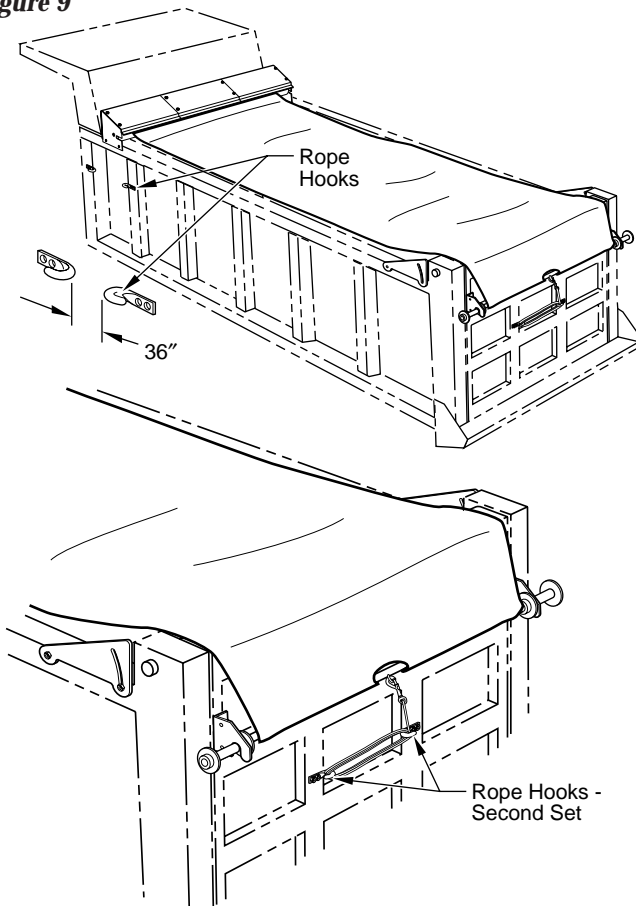

OPTIONAL STEP 8

Installing the Adjustable Mounting Brackets

Parts you will need:

Mounting brackets assembly (2)

$\frac{5}{16}$ " x 1" hex bolt (4)

$\frac{5}{16}$ " lock washer (4)

$\frac{5}{16}$ " hex nut (4)

Note: This assembly is used to mount the system to an area (cab shield) which is narrower than the dump body.

1. See figure 10. If you have purchased the optional mounting bracket kit, mark down 2" from the top of the cab shield and line up the bottom edge of the bracket at that line. Clamp into position. Using the holes in the brackets as a guide, drill $\frac{11}{32}$ " holes into the dump body or cab shield. Bolt the brackets into place using the $\frac{5}{16}$ " x 1" bolts, washers, and nut. Adjust to match width of the outside of the dump body.
2. Mount the tarp housing assembly to the brackets using the procedures outlined in Step 5.

Figure 10

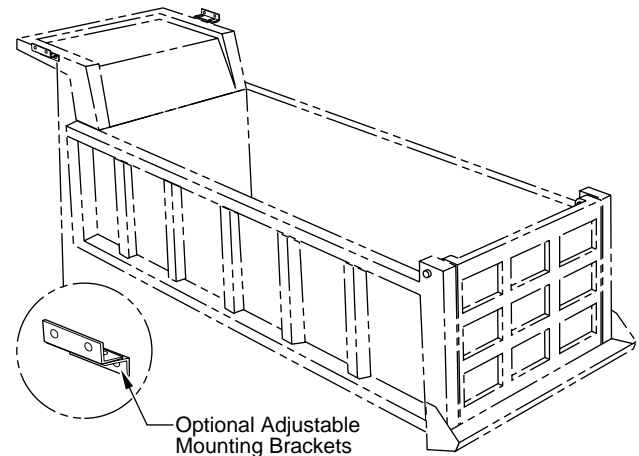

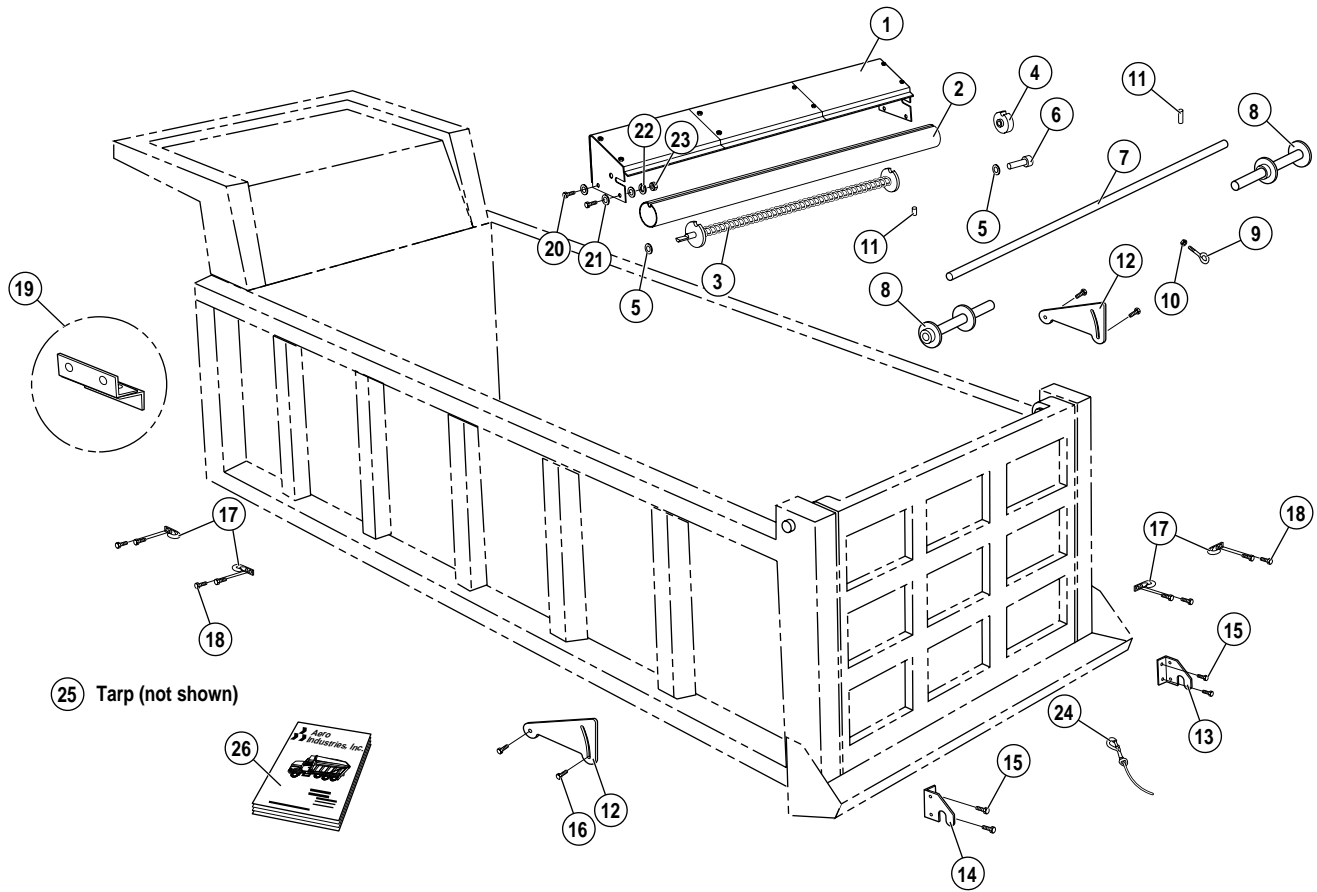

Sub-Assembly #0321-961104

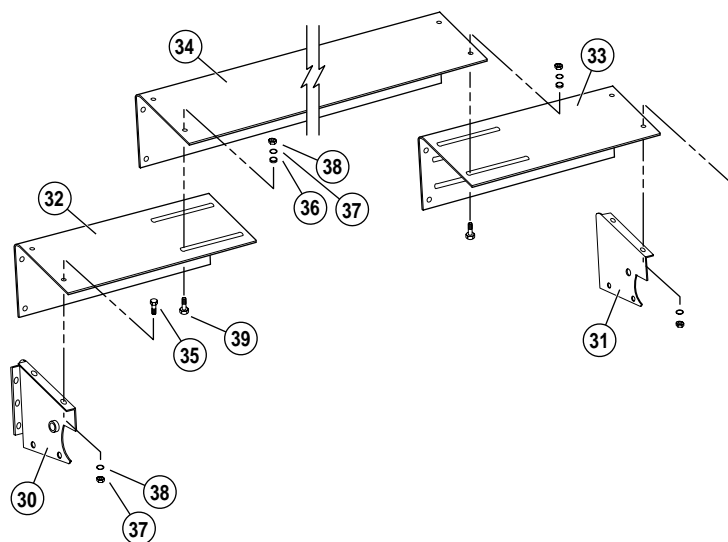

No.	Part No.	Description	Qty.	No.	Part No.	Description	Qty.
1	0321-961104	Tarp Housing Assy	1	21	0820-680510	Washer Flat 5/16	8
2	1350-148346	Alum Extrusion 3 1/4" Dia x 102"	1	22	0820-680520	Washer Split Lock 5/16	4
3	0321-961103	Spring Assembly	1	23	0815-660510	Nut Hex 5/16	4
4	0321-961110	Casting Assy Outside	1	24	0321-961115	Pull Rope Assembly	1
5	0820-680222	Washer Thrust 1/2 x 3/16 Nylon	2	25		Tarp (Not Shown)	1
6	0835-619634	Pin Clevis 1/2 x 2 1/2	1	26	0930-861518	Installation Instructions Easy Pull	1
7	1350-148347	Alum Extr .782 ID x 84"	1	Sub-Assembly Parts #0321-961104			
8	0321-961002	Roller Assembly Puller Bar	2	No.	Part No.	Description	Qty.
9	0810-650915	Bolt Eye 1/4 x 1 1/2	1	30	0321-961100	End Plate Assy D.S. Easy Pull	1
10	0815-660451	Nut 1/4-20 Nylon Lock	1	31	0321-961101	End Plate Assy P.S. Easy Pull	1
11	0835-691618	Pin Spring 1/4 x 1 1/4	2	32	0321-861106	Top Plate D.S. Easy Pull	1
12	0321-861113	Ramp Hinge Block	2	33	0321-861107	Top Plate P.S. Easy Pull	1
13	0321-861112	Lock Plate Rear P.S.	1	34	0321-861108	Top Plate Center Easy Pull	1
14	0321-861111	Lock Plate Rear D.S.	1	35	0810-650515	Bolt HHCS 5/16-18 x 3/4 HHCS	10
15	0825-650620	Bolt HWH 3/8 x 1 1/2 Self Tapping	4	36	0820-680510	5/16" Flat Washer	8
16	0810-650510	Bolt HWH 5/16 x 1 Self Tapping	4	37	0820-680520	5/16" Split Lock Washer	18
17	0730-612360	Hook "J" Tarp Hook	4	38	0815-660510	5/16" Hex Nut	18
18	0825-670450	Bolt HWH 1/4 x 1 Self Tapping	8	39	0810-650508	Bolt Carriage 5/16-18 x 3/4	8
19	0321-961109	Mounting Plate Assy (Optional)	2				
20	0810-650514	Bolt HHCS 5/16-18 x 1	4				

You're Covered With Aero!

WARRANTY

Aero products come with a one year warranty on all parts. It's another example of our ongoing commitment to customer satisfaction and quality.

CUSTOMER SERVICE

1-800-535-9545

Our customer service technicians are trained to help you. Whether it's ordering, installation, or just general information on our products, you can count on expert advice from Aero.

© 2000 AERO INDUSTRIES, INC

0930-861518

6/15/00



INDIANAPOLIS
3010 W. Morris Street
P.O. Box 21066
Indianapolis, IN 46221
(800) 535-9545
FAX (317) 244-1311

OMAHA
I-80 & Highway 50 South
P.O. Box 37598
Omaha, NE 68137
(800) 535-8552
FAX (402) 895-6129

HAMBURG, PA
2nd & Grand
Hamburg, PA 19526
(800) 535-3665
FAX (215) 562-0340

PHOENIX, AZ
3836 W. Buckeye Rd.
Phoenix, AZ 85009
(888) 224-8277
FAX (602) 233-2929

BURLINGTON, ONTARIO
AERO-KIT INDUSTRIES
3474 Mainway Drive
Burlington, Ontario
L7M 1A8
(905) 335-2012
FAX (905) 335-8499