

Side Kit: Commodities Hauler

OWNER'S MANUAL

Installation, Safety, and
Maintenance Instructions

READ THIS ENTIRE MANUAL PRIOR TO INSTALLATION

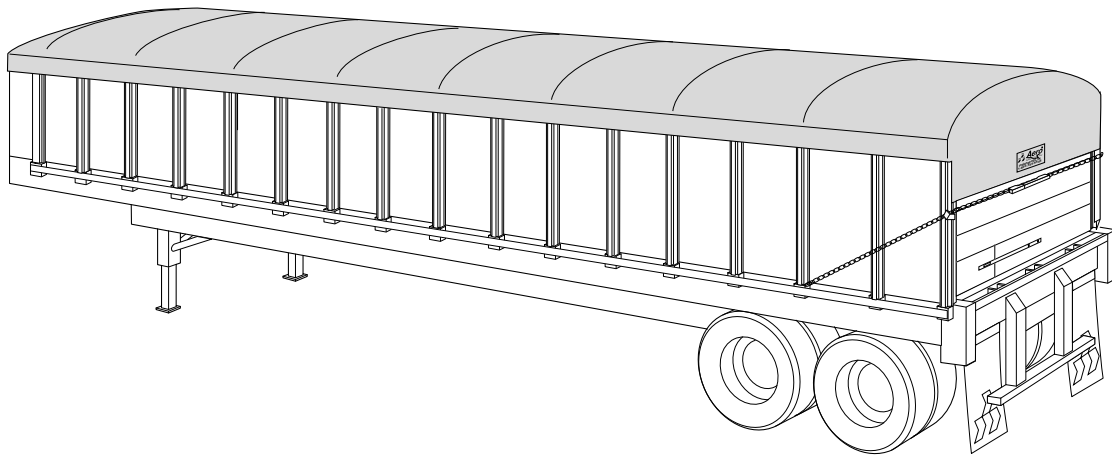

Attention Dealers:

Please give these instructions
to the customer when the
product is delivered.

• Indianapolis, IN • Omaha, NE • Streetsboro, OH



Side Kit: Commodities Hauler

IMPORTANT: This manual explains how to install and maintain the Side Kit designed for flatbed trailers.

Be sure to read the entire manual before beginning the installation.

Three kinds of special explanations will appear in these instructions. Be sure to read and follow them.

⚠ WARNING: Possible danger to the operator or bystander. The operator or bystander could be injured if you ignore this information.

CAUTION: Risk to the product. If you ignore this information the Product or the Vehicle could be damaged.

NOTE: *Contains additional information about a feature or step critical to the installation of this product.*

TOOLS REQUIRED FOR INSTALLATION

Circular Saw
Air or Electric Drill
5/16" Drill Bit
1/2" Open End or Box Wrench
1/2" Socket
3/8" or 1/2" Drive Ratchet
Center Punch
Hammer
24" Square
Welder (Aluminum or Steel)
* Denotes If Additional Pockets are Required.

⚠ WARNING: The aluminum stakes on this side kit have been pre-cut in our factory to fit the trailer pockets that were specified on the order. Any modification to these stakes WILL void the warranty unless those modifications have been pre-approved by our customer service department.

To order replacement parts call Inside Sales Department at 1-800-535-9545

Aero Warranty

Aero Products come with a one year warranty on all parts. It's another example of our on going commitment to customer satisfaction and quality.

Tarp Warranty

Aero Industries, Inc. recommends using rope tie downs with your Aero tarp. Rope ties downs should be used at all times. If rubber tie downs must be used, use a minimum of 5 ties per side. DO NOT use rubber tie downs on the front of the tarp. Failure to follow these guidelines will void the tarp warranty.

Side Kit: Commodities Hauler

Trailer Preparation - Before You Begin

1. Be sure that the stake pockets on the trailer are on 24" centers to accept the 48" center to center panels.
2. Be sure that the stakes are the proper size for your stake pockets.
3. Make sure you have all the tools listed above available.
4. Make sure there is a flat clean surface where the side kit panels will sit on the top rail.
- 5a. If you are installing the side kit on a trailer with an existing bulkhead, it may be necessary to modify the bulkhead prior to side kit installation as shown on page 3.
- 5b. If you are installing an Aero bulkhead, install the bulkhead per Aero's instructions and proceed to STEP 1.
6. If you are installing a kit on a 96" trailer, there must be a center stake pocket on the rear or if you are installing a 102" trailer, there must be two stake pockets on the rear as shown on page 2.
7. Check that the last stake pocket at the rear is flush with the back of the trailer as shown on page 2.

NOTE: During certain steps such as fitting the rear end, it may be necessary to make a trailer modification, such as moving or installing another stake pocket or trimming a panel to fit. Aero Side Kits fit well on most trailers with little or no modifications. However, should modifications be necessary, Aero Industries, Inc. will not be responsible for costs incurred to make these modifications without express written authorization.

Modification of Bulkhead (If Required)

Parts you will need:

1. "Z" Shaped Adapter

1. **See Diagram 1.** Weld or bolt (bolts not included) the "Z" adapters to inside of the bulkhead at the end of the return on both sides.

Diagram 1

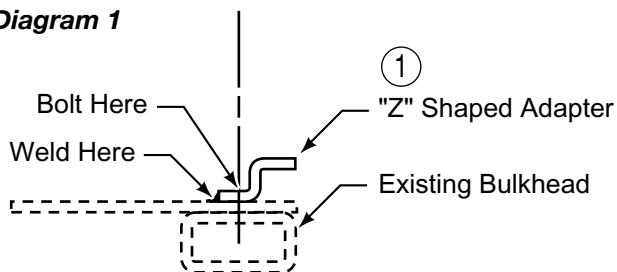

Addition of Rear Pockets and Moving of Side Rear Pocket (If Required)

Parts you will need:

2. Stake Pockets (not included)

1. **See Diagram 2.** Weld any additional pockets on the rear of the trailer if required.

1. **See Diagram 2.** Move the last side stake pocket to the rear if required.

Diagram 2

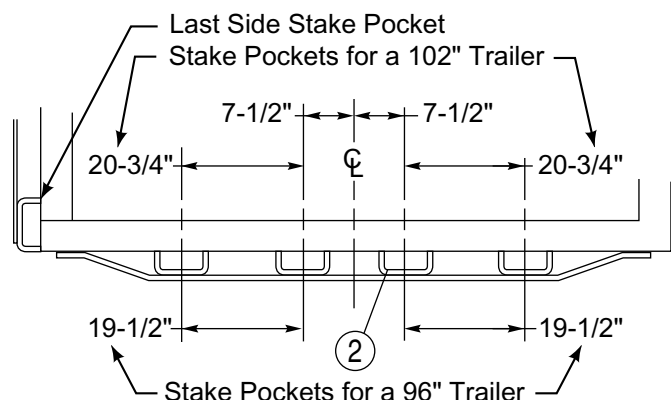

Side Kit: Commodities Hauler

Aero offers 3 Aluminum Stake Styles

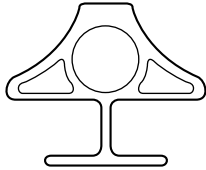

Senior

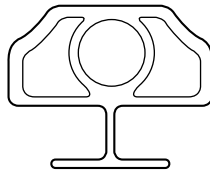

Square

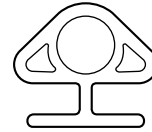

Junior

Aero offers 3 Panel Styles

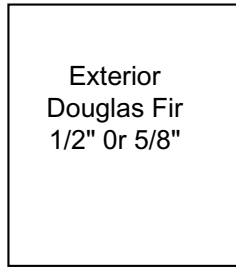

Exterior
Douglas Fir
1/2" Or 5/8"

Exterior
Douglas Fir

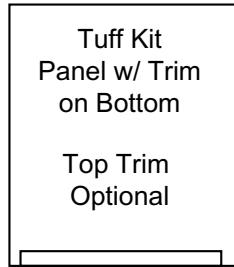

Tuff Kit
Panel w/ Trim
on Bottom

Top Trim
Optional

Fiberglass
Tuff Kit
w/ Plywood Core

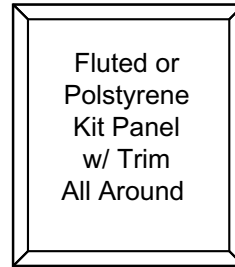

Fluted or
Polystyrene
Kit Panel
w/ Trim
All Around

Fluted or
Polystyrene Core
(Light Weight)

Procedures to Cut Down Various Panels

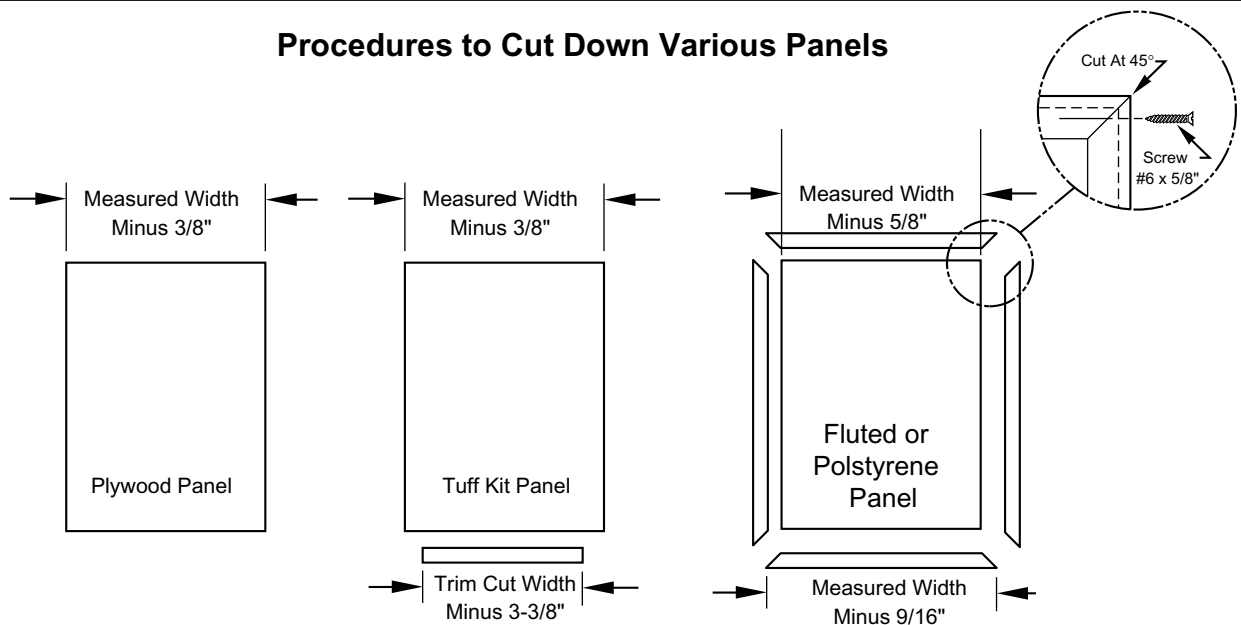

Side Kit: Commodities Hauler

STEP 1 - Installing Stakes and Panels

Parts you will need:

- | | |
|---|--|
| 1. Corner Stake D.S. w/o Tarp Stay Holder (1) | 4. "T" Stakes w/o Tarp Stay Holder (Qty. Varies) |
| 2. Corner Stake P.S. w/ Tarp Stay Holder (1) | 5. Side Panels (Qty. Varies) |
| 3. "T" Stakes w/ Tarp Stay Holder (3) | 6. Plain Stakes (Qty. Varies) |

NOTE: Stakes and panels are supplied to cover the full length of the trailer on each side and across the rear. If the stake pockets are not on typical 24" centers, additional stakes need to be purchased and some panels will need to be cut to size. Every other stake pocket must not exceed 48" center to center.

NOTE: Always begin the side kit installation at the rear corners of the trailer

1. **See Figure 1.** Insert the D.S. corner stake (w/o stay holder) into the last pocket at the rear of the trailer. Insert a "T" stake (w/o stay holder) in the second pocket forward (48" center to center). Slide a panel down into the slot in the cornerstake and the slot in the "T" stake. Make sure the bottom of the panel is tight against the trailer rail. Repeat installing stakes and panels leaving the last panel next to the bulkhead for installation later. Install a plain stake in the center of each panel into the unused pockets, with the clip on the top of the stake grabbing the panel at the top.

NOTE: If a full panel can not be used at the rear, it will be necessary to cut a panel to fit between the corner stake and the "T" stake. Measure the opening between the "T" stake and the corner stake. Cut a panel to fit. **See stakes and panels on page 3.**

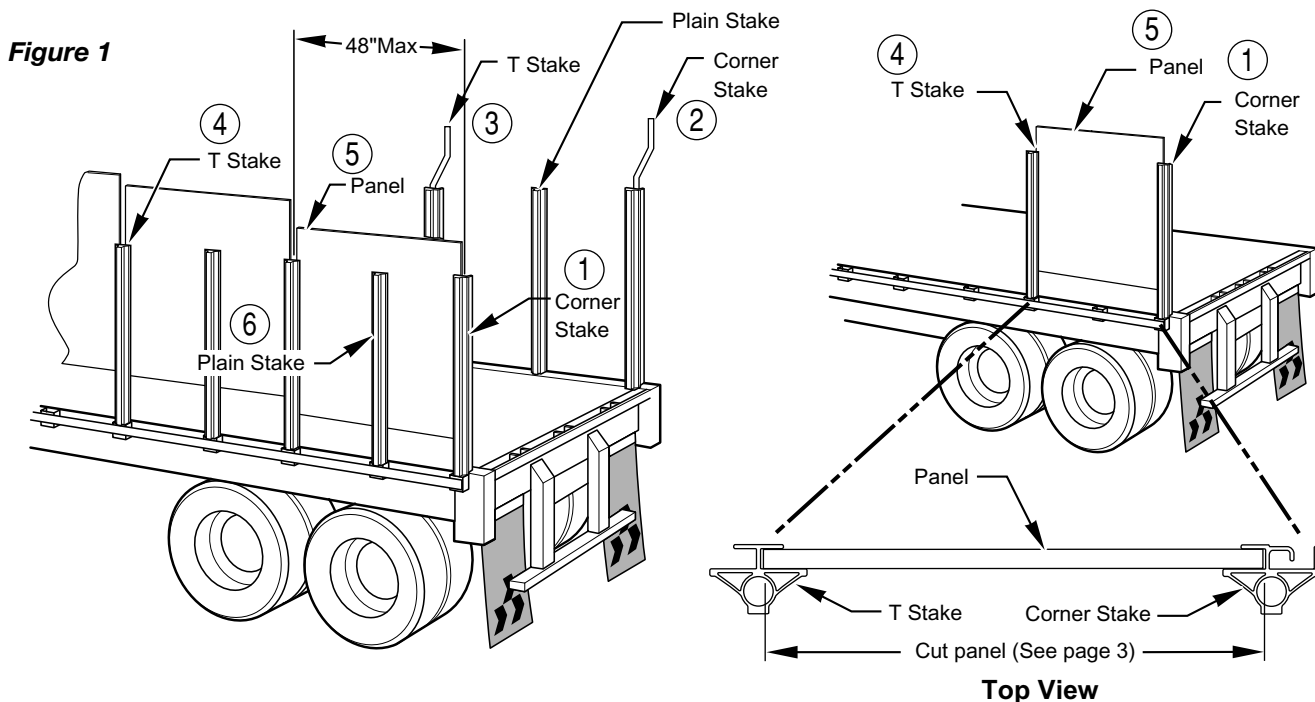

Side Kit: Commodities Hauler

On the passenger side, insert the corner stake (w/ stay holder) into the rear of the trailer. Repeat installing "T" stakes and panels as described in STEP 1. Make sure that there is a "T" stake with a tarp stay in the last pocket next to the bulkhead and the other two are spaced evenly from front to back.

1. **See Figure 2.** Measure the distance between the slot in the "T" stake and the slot on the bulkhead. Cut the panel to fit. **See stakes and panels on page 3.**

Figure 2

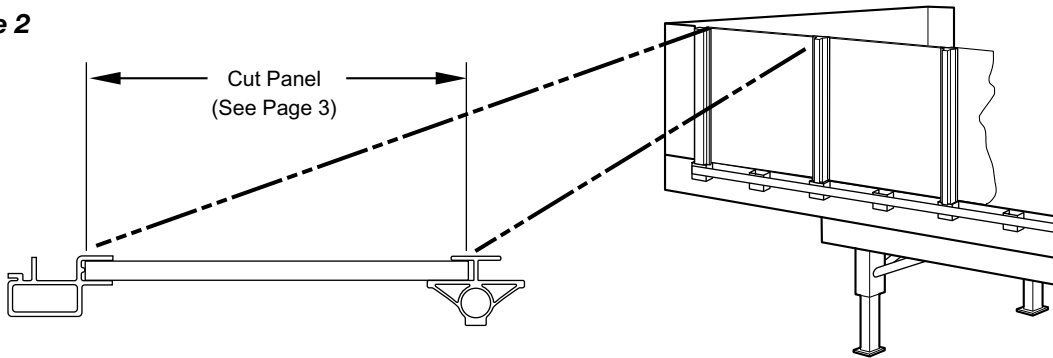

STEP 2 - Installing the Bows

Parts you will need:

1. **Bow Lower Rise (1)**
2. **Bow Maximum Rise (Qty. Varies)**

1. **See Figure 3.** Starting at the front of the trailer, insert the lower arched bow into the rear bow holes on the Aero bulkhead or into the two bow pockets supplied. (For an existing bulkhead, install these bow pockets at the rear of the side wrap.)

2. Insert the remaining bows into the tops of the "T" stakes and rear corner stakes, pushing downward as far as possible into the stakes on each side of the trailer. This will give the tarp a smooth look when it is installed.

Figure 3

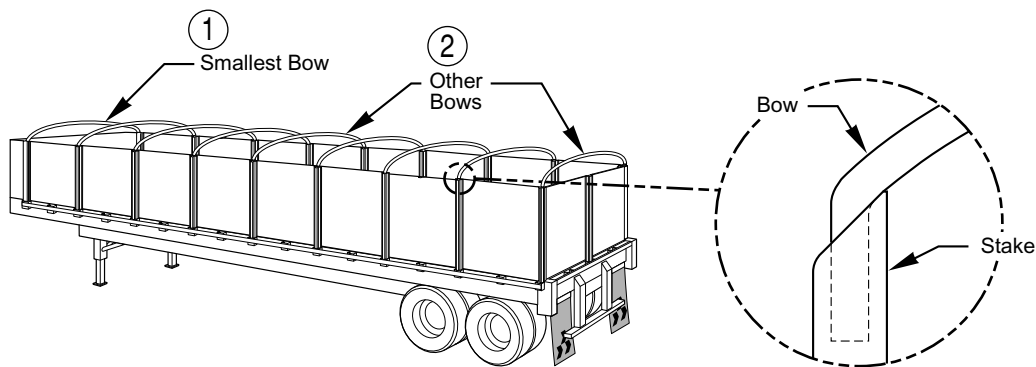

Side Kit:Commodities Hauler

STEP 2 - Installing Rear Planks

Parts you will need:

1. Hinged Plank 12" (1) 2. Plank 10" (4) 3. Chain and Binder

1. See **Figure 4**. Measure the distance between the two rear corner stakes. Cut off boards 1/4" less than that measurement for play. Insert the 1/2" hinged board on the bottom with the breakaway handle on the outside. Cut the 10" boards and place them horizontally above the hinged board, one on top of the other until the opening is filled. Secure the board above the hinged board with screws as shown.

Figure 4

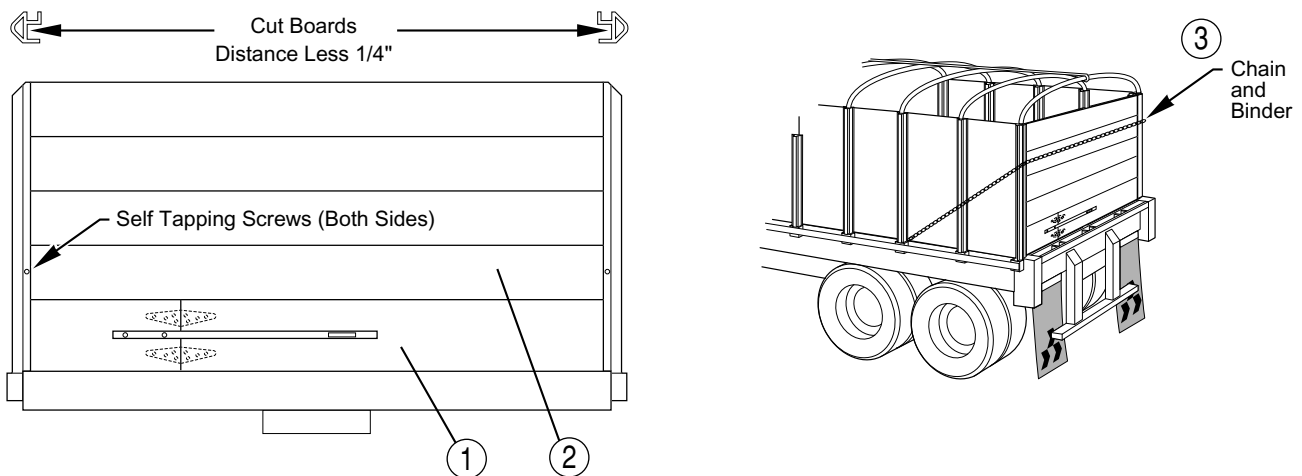

STEP 2 - Installing Rear Panels

Parts you will need:

1. "T" Stakes (2)
2. Plain Stakes (2)
3. Panels

1. Cut panel to fit between corner stakes.
2. Measure the distance between the "T" stakes and corner stakes and cut two panels to fit. **See stakes and panels on page 3**. Slide the panels into the "T" stakes and corner stakes.

Figure 5

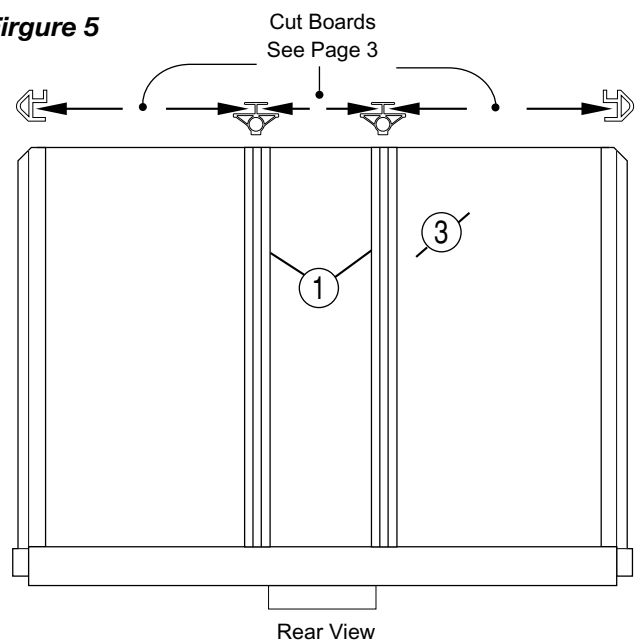

Side Kit: Commodities Hauler

STEP 5 - Installing the Roof Strap and Tarp

Parts you will need:

1. Roof Strap (1)
2. Tarp (1)
3. Ropes (Qty. Varies)

* Denotes Not Shown in Figure 5

1. **See Figure 6.** Attach the metal mounting bracket on the roof strap to the center of the bulkhead by drilling a 5/16" hole and using a 5/16" bolt long enough to go through the bulkhead and bracket. Secure the other end of the roof strap (with adjustable buckle and loop) by feeding the last bow on the rear through the loop of the strap. Pull the strap tight the top of the bows and secure with the adjustable buckle. The roof strap will help support the tarp and avoid pockets of moisture on the tarp during wet weather.

2. Install the tarp on the trailer by unrolling the tarp from front to rear over the trailer. Pull tight and secure by rope or straps to the rub rail of the trailer.

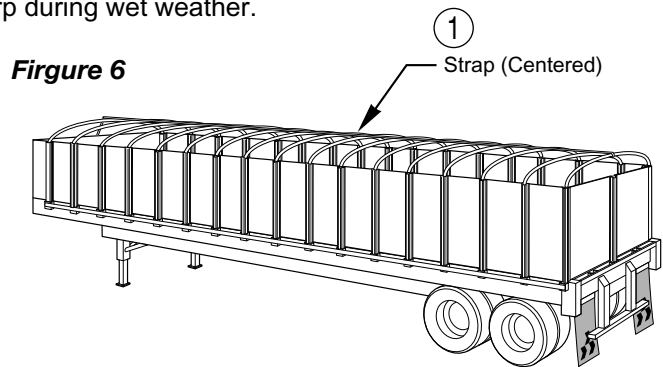

STEP 6 - Installing the Roof Strap and Tarp

Parts you will need:

1. Tarp Stays (4)
2. Cotter Pins (4)

1. **See Figure 7.** Install the tarp stays into the holders located on the four stakes installed on page 5.

NOTE: Tarp stays are standard on the passenger side. Driver side is optional.

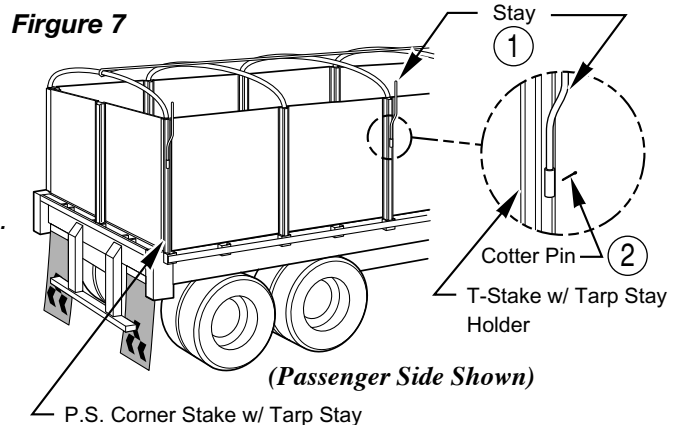

How to Maintain the Side Kit

1. Be sure to keep the tarp taut at all times while in use.
2. Inspect the panels for damage occurred during use and replace when required.
3. Inspect the tie down ropes or straps for wear and replace as required.
4. Inspect aluminum stakes and bows for damage and replace as required.

Side Kit: Commodities Hauler

Hardware Bill of Materials

Part Number	Part Description	Qty.	Part Number	Part Description	Qty.
Varies	Corner Stake D.S.	1	Varies	Panels	Varies
Varies	Corner Stake P.S. w/ Stay Holder	1	Varies	Tarp	1
Varies	"T" Stake w/ Stay Holder	4	Varies	Roof Strap	1
Varies	"T" Stake w/o Stay Holder	Varies		Tarp Stays	4
Varies	Bow Front	1		Pin Cotter	4
Varies	Bow High Rise	Varies			

Aero Industries, Inc.  **Aero**[®]

INDIANAPOLIS, IN. - 4243 Bradbury Ave., Indianapolis, IN 46241 - 800-535-9545 - FAX: 317-244-1311

OMAHA, NE. - I-80 & Highway 50 South, Omaha, NE 68137 - 800-535-9545 - FAX: 402-895-6129

STREETSBORO, OH. - 8540 State Route 14, Streetsboro, OH. 44241 - 888-237-2262 - FAX: 330-626-3277

Aero Kit - BURLINGTON, ON. - 5499 Harvester Road, Burlington, ON. L7L 5V4 - 800-465-8277 - FAX: 905-335-8499