



Rolling
Tarp Solution



PRODUCT INNOVATION

SINCE 1944

AERO INDUSTRIES

Groundbreaking engineering that sets the bar

One of the nation's leading providers of innovative accessories for the transportation industry, Aero manufactures a complete line of American-made products for dumps, flatbeds, agriculture, refuse and other trailer applications. Our Indianapolis, Indiana headquarters is a state-of-the-art manufacturing facility with over 140,000 square feet of space.

Aero's history as a leader in the industry includes the introduction of the first aluminum stake Side Kit, the first open top and dump side-to-side roll tarps, and the first rolling tarp system, the Conestoga, in 1984.

Over 30 years of continued research and development has ensured that the Conestoga remains the best rolling tarp system on the market today.

MODELS AVAILABLE FOR:

Flatbeds

Drop Decks

Straight Trucks



AERO[®] CONESTOGA

30" SOLID SHEET REAR BOW

rear bow has full exterior sheet for additional strength, ease of rolling and final tarp installation adjustments

30" FRONT BOW

for stability and ease-of-rolling

**SAFE.
FAST.
VERSATILE.**

REAR LOCKS TRAVEL WITH THE BOW

allowing full access to trailer side-loading



THE ORIGINAL ROLLING TARP SYSTEM

SINCE 1984

LATCH LOCKS

*allows for opening and closing
without touching the rear locks**

BULKHEAD

*DOT and non-DOT options
available to meet your needs*



STAINLESS STEEL TRACK AND STEEL WHEELS

utilizing our unique V-groove design

PANELIZED TARP

one-piece look with minimized maintenance costs

AERO CONESTOGA | PATENTS

United States:

4711484, 4902064, 5538313, 6419301, 6793273, 7229120,
7249796, 7325855, 7494177, 9815506

Canada:

1290786, 2159749, 2610565, 2625980

Other patents pending

** with use of the rear Speed Lock*



DROP DECK MODEL



DROP DECK MODEL
tarp to rear / hybrid model shown



DROP DECK
tarp to front



FLATBED MODEL
shown with optional skylights

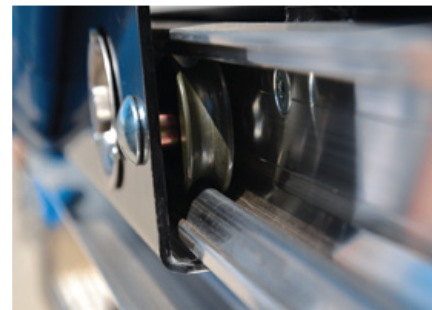

CUSTOM GRAPHICS
available upon request



STRAIGHT TRUCK MODEL
shown without sheeted rear bow

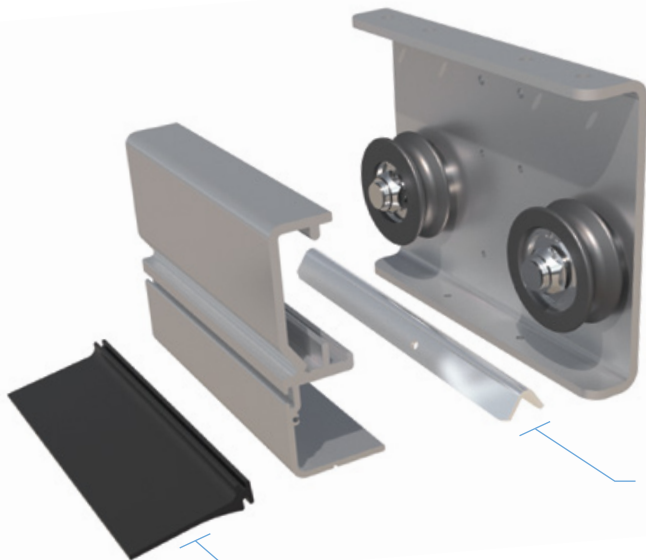

STEEL V-GROOVE WHEELS
*with double sealed bearings
and a lifetime warranty*

**STAINLESS STEEL
V-GROOVE TRACK INSERT**

RUBBER SEAL
*seals under the stake pockets
for access and protection*

WHEEL AND TRACK SYSTEM

1

TRACK DESIGN INCREASES SYSTEM LONGEVITY

The Conestoga was designed to house the wheels within the track system, providing increased wheel protection from the trailer load and outdoor elements.

The stainless steel track and steel V-groove shaped wheels allow the operator to fully open and close the system with ease.

Wheels are not exposed to the elements

Steel on Steel = Ease of rolling and less maintenance

BOW J-CLAMP
*keeps tarp secure and
system sealed*

BUMP RAIL
*protects the track and
seals the tarp*

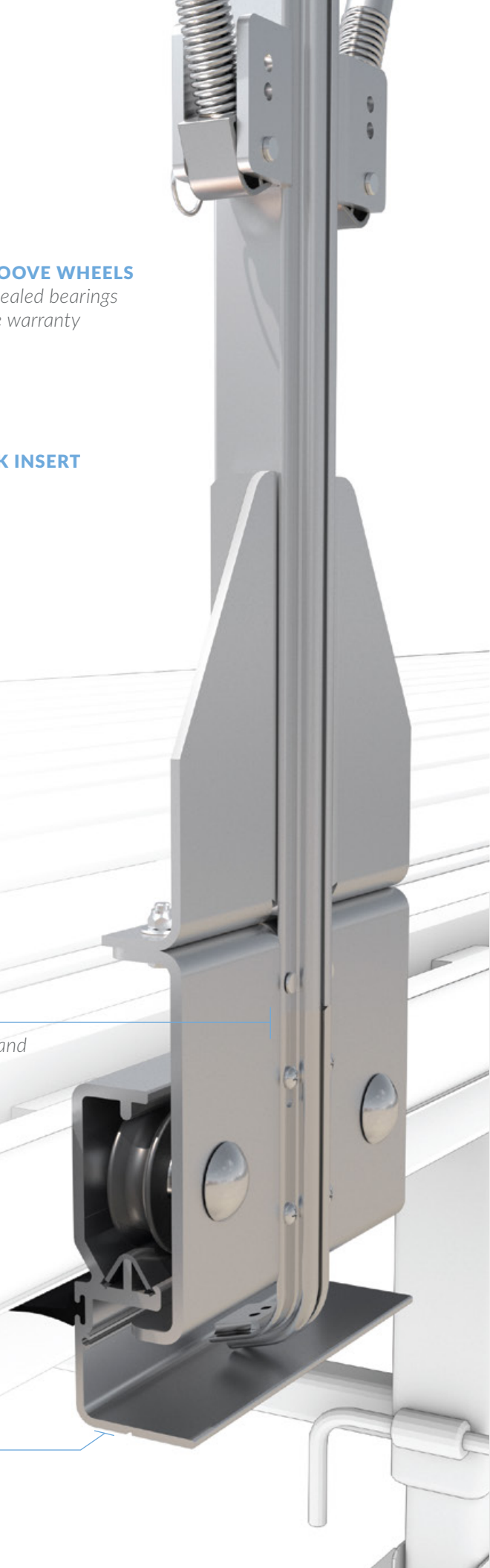

INDUSTRY'S UNDISPUTED BEST WHEEL AND TRACK SYSTEM

The track and wheel design utilizes a unique 'V' groove, eliminating the need for numerous, secondary guide wheels. This design also eliminates wheel 'flat spots' commonly seen in competitor models.

A built-in bump rail reduces impact damage and further maximizes overall system longevity.

28

VS COMPETITOR'S

74

WHEELS ON 48' SYSTEM

Steel on steel wheel and track design

V-groove wheels will not flatten

Lifetime warranty on all wheels and bearings

INTERNAL WHEEL TRACK SYSTEM

wheels are positioned below the loading deck surface

V-GROOVE WHEELS

heavy duty and long lasting with no need for secondary guide wheels

STAINLESS STEEL V-GROOVE TRACK INSERT

provides ease of rolling and long life resulting in reduced downtime and maintenance costs

RUBBER SEAL

allows for use of stake pockets while providing a weathertight seal

BUILT-IN BUMP RAIL

protects the track from side loading and works with the j-clamp to create a watertight seal

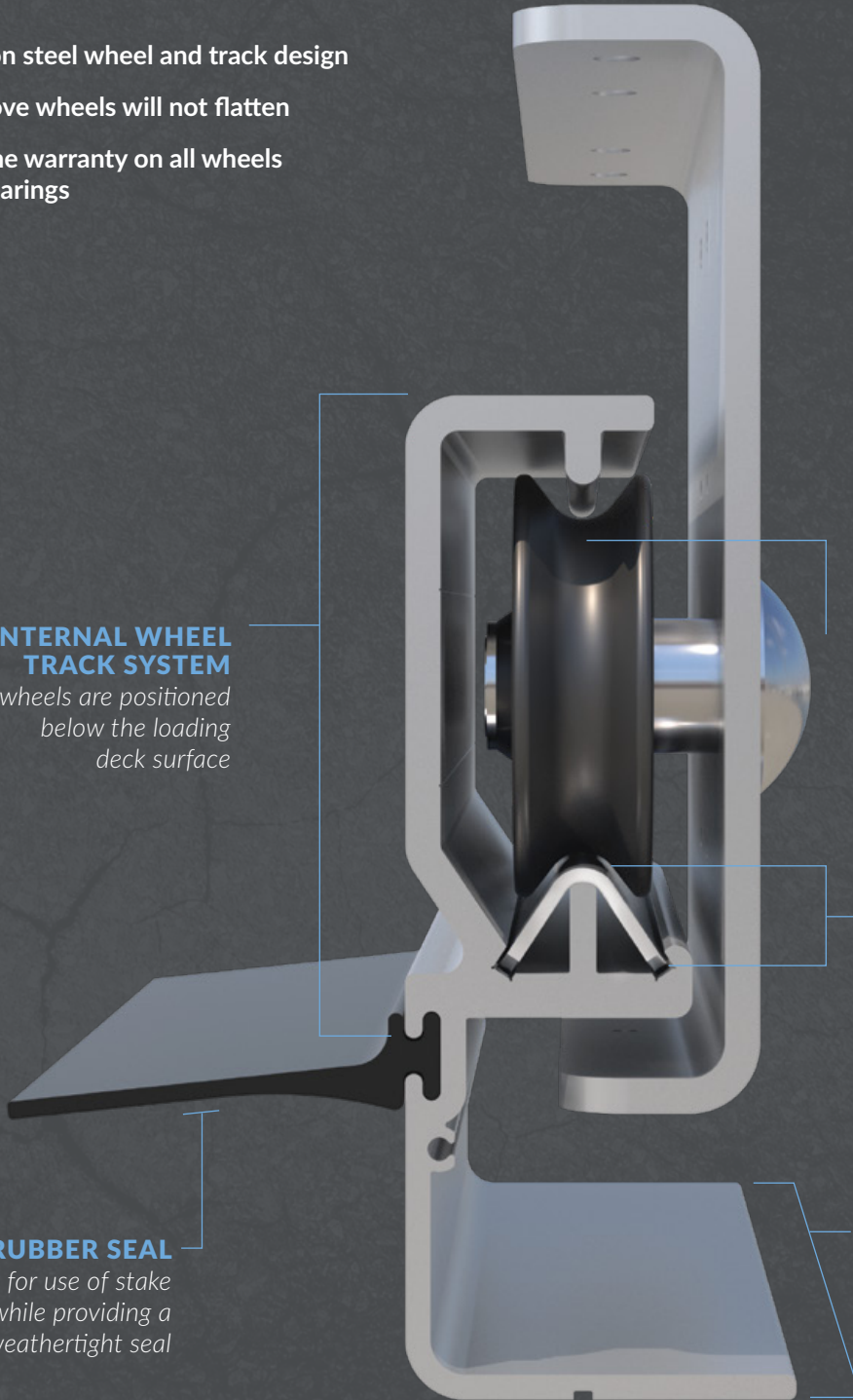

2

TWO GREAT REAR LOCKS

TENSION LOCK | Screw drive operation

The Tension Lock allows the system to be opened or closed using a removable crank handle.

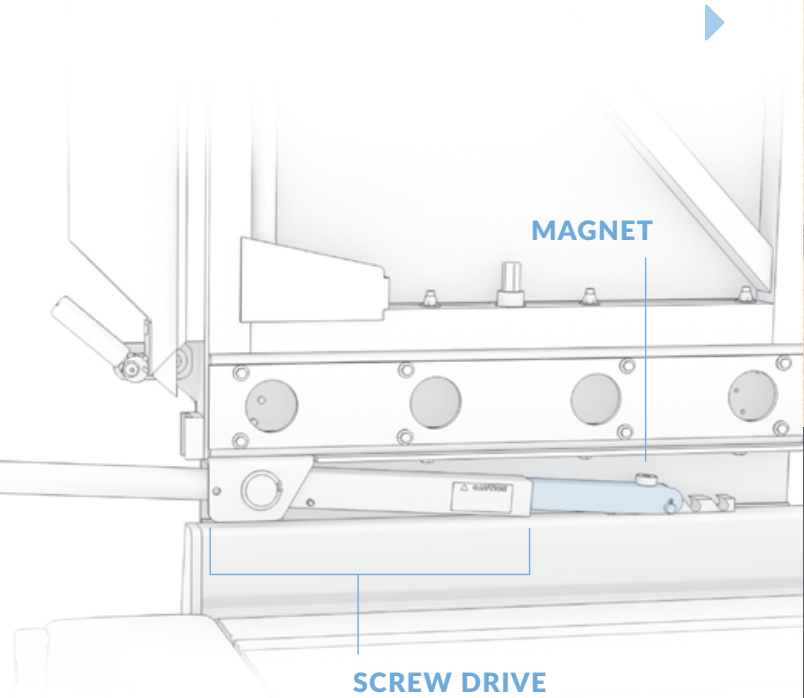
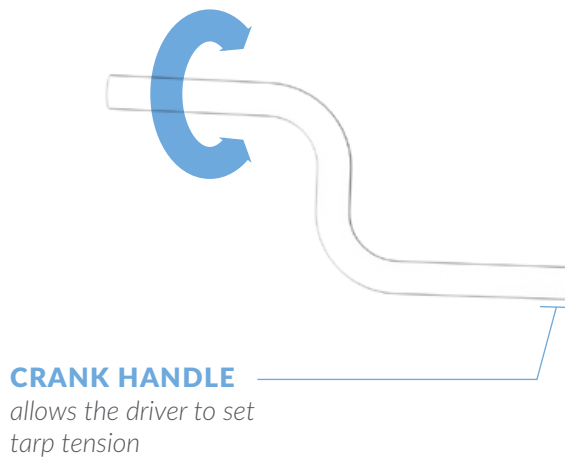

SPEED LOCK | Over-center operation

The Speed Lock allows the system to be opened or closed with a single motion of a handle or winch bar. The Speed Lock allows for the operation of the front locks without first releasing the rear locks.

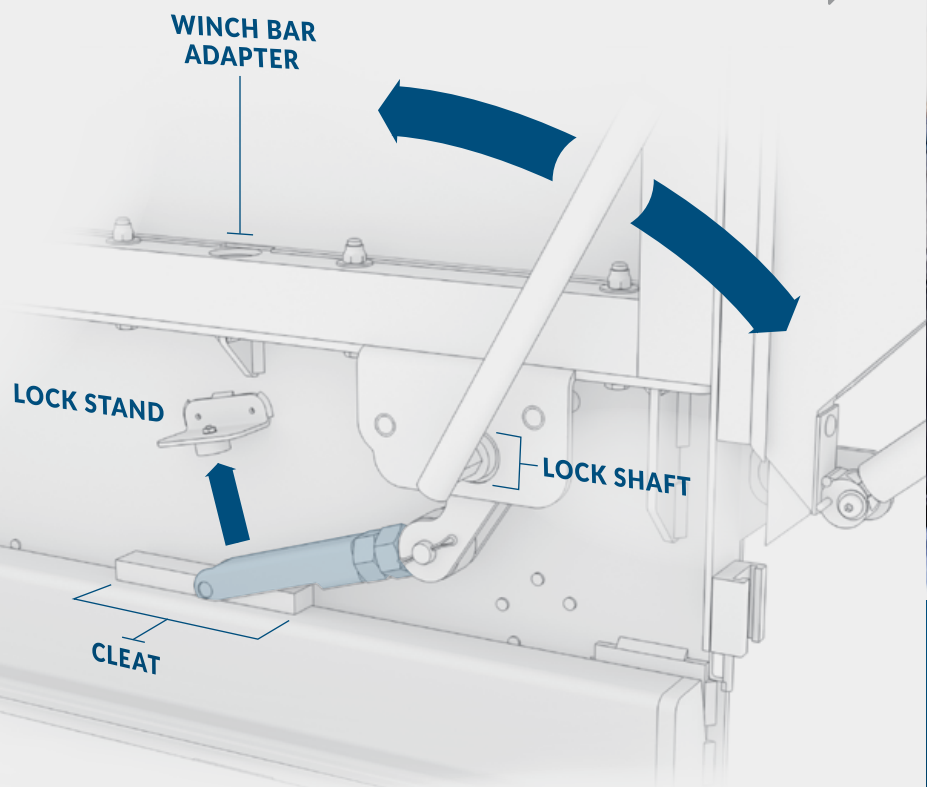

NO SPECIAL TOOLS NEEDED

operator can use a winch bar



TENSION LOCK

allows for optimal tarp tension

All lock components travel with the rear bow

Screw drive allows system to be locked for optimal tarp tension

No secondary adjustments required

Operated completely from the ground



SPEED LOCK

saves operational time and money

All lock components travel with the rear bow

Allows unlocking front without first unlocking rear

Single motion release from either inside or outside the rear bow

No special tools needed—operator can use a winch bar

3

LATCH LOCK ALLOWS FOR EASY OPENING AND CLOSING OF THE FRONT BOW TO THE BULKHEAD

A double hinged Latch Lock tightly secures the front bow to the bulkhead while ensuring a watertight seal.

Latch Locks are operated from the ground for increased safety. When using the rear Speed Lock, Latch Locks allow operator to open and close the Conestoga without first releasing the rear locks.

Handles are built-in for ease of operation

Stainless steel cane bolt securely locks handle

Heavy duty components provide security and low maintenance

Engineered using minimal components for reduced maintenance

HEAVY DUTY
CANE BOLT

BUILT-IN
HANDLE

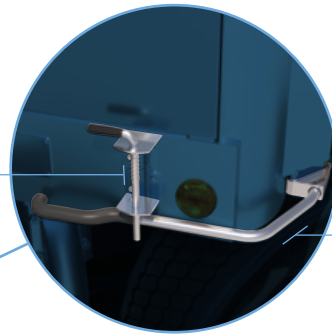

LATCH LOCK

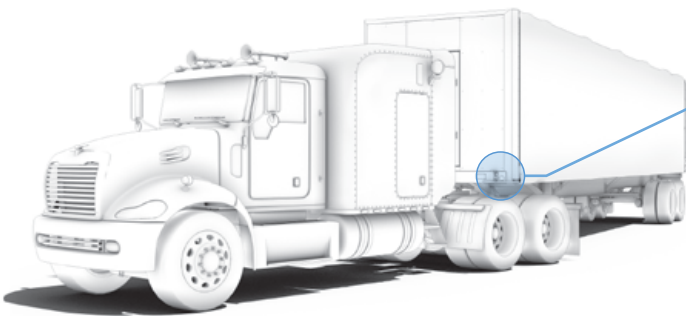

4

UPLIFT BOW AND ASSEMBLIES

UPLIFT BOWS REDUCE TARP SAG

Uplift bows are designed to reduce tarp sag and maximize internal load clearance. Spring shocks on the Conestoga uplift bows absorb vibrations from road conditions and extend system and tarp life.

Maximizes inside loading clearance by reducing tarp sag

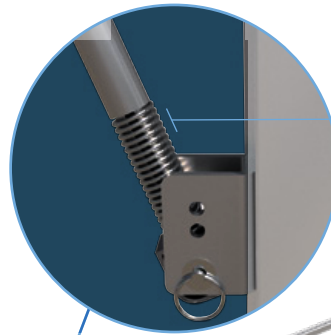

SPRING SHOCK

maintenance free – no bushings to repair or replace

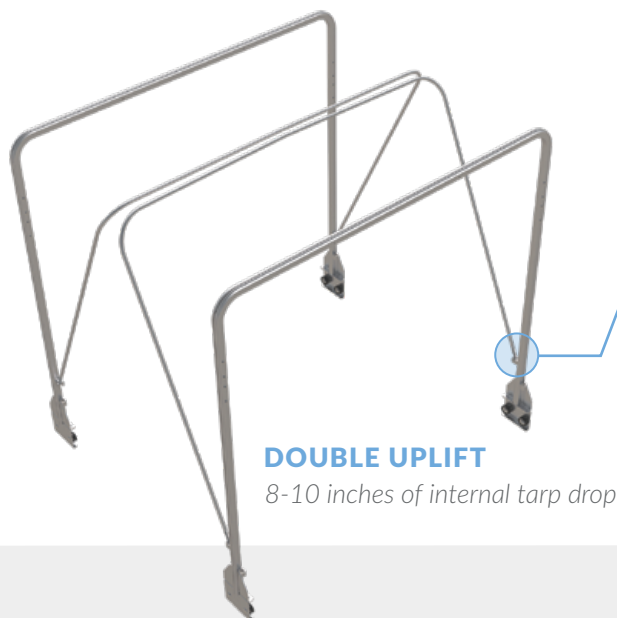

DOUBLE UPLIFT

8-10 inches of internal tarp drop

optional quints available



QUAD UPLIFT

4-5 inches of internal tarp drop

5

ROBUST 30" FRONT AND REAR BOWS

The front and rear bows of the Conestoga were designed to be 30" wide, resulting in increased ease of rolling and added stability when compared to systems with narrow bows.

Rear bow has full exterior sheet for additional strength and final tarp installation adjustments

Available without full exterior sheet and adjustable tarp clamp



6

BULKHEAD AVAILABLE IN BOTH DOT AND NON-DOT MODELS

Non-DOT bulkheads are available with or without access doors. Access doors are available as both standard and heavy duty.

NOTE: Any bulkhead with a door is non-DOT rated. Bulkhead access doors are 6 x 3 feet.

**Industry's Only DOT rated bulkhead to meet both the U.S. Department of Transportation width regulation 658.16 (b)(2)(vi) and standard 393.114 (c)(2) for loads up to 50,000 lbs.*

BULKHEADS

Sleek, smooth aerodynamic design to reduce drag and increase fuel efficiency

Built-in front lock assemblies for maximum loading clearance

Available with optional chain racks and trays

Optional polished aluminum front sheets available for all models

STANDARD NON-DOT WITHOUT DOOR



STANDARD NON-DOT WITH DOOR (T-handle locks)



STANDARD DOT (not available with door)*



HEAVY DUTY NON DOT WITH DOOR (stainless steel lock rod)

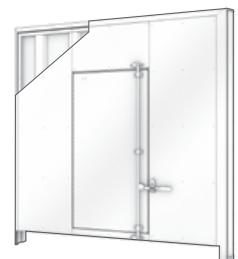

STANDARD NON-DOT with access door



HEAVY DUTY NON-DOT with access door



HEAVY DUTY NON-DOT with access door

AERORAD AND CURTAINS

7

AERORAD

AeroRad duals as an aerodynamic rear end device that reduces drag and saves valuable fuel.

AeroRad also secures the curtain to the rear bow for a watertight seal.

No buckles, straps, velcro or bungees required

Simple and fast over center cam lock

AERORAD

CAM LOCK

CURTAINS

The Conestoga offers two rear curtain options—a Roll and a Pull curtain. Choose the way you want to operate the rear based on your needs and preferences.

ROLL CURTAIN

Crank handle operation

Stores on top of the system providing full rear opening and clearance

Underbody handle storage included



PULL CURTAIN

Rope and pulley operation

Offers simple, easy operation without requiring a crank handle

Does not provide full height clearance for rear loading





Flatbed Family of Products

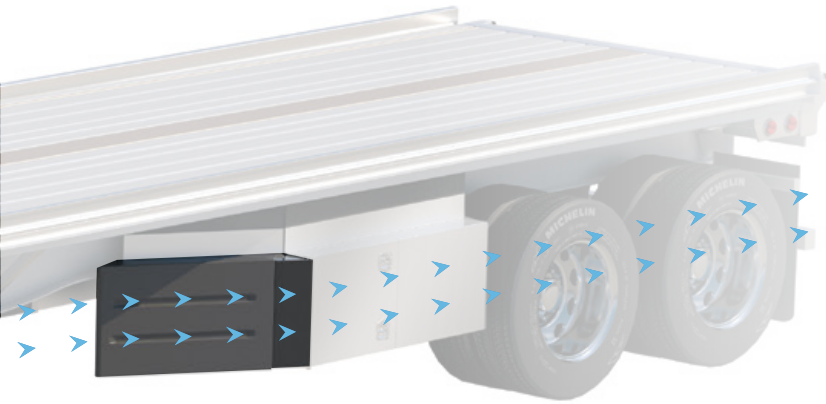

AERO FAIRING

Our Aero Fairing was designed to seamlessly integrate with any underbody tool box—including our durable AeroBoxes—providing increased fuel savings for your flatbed trailer.

United States Patent 9815506

AERO BOX

We manufacture storage boxes at nearly any size for any type of truck or trailer. They stand tough through the harshest road environments and still look great. Whatever you need to protect, you'll find an Aero storage box that's more than up to the job.



AERO BULKHEAD

Industry's leading DOT bulkhead available in 10" and 22" wrap models. Aero makes a complete line of good-looking, hard-working bulkheads to fit your needs.



SIDE KITS

Aero's Side Kits are the strongest and lightest you can buy, with every component engineered for the job it's intended to do. If you have a load to haul, Aero has a Side Kit to keep the weather out and your load safe.

ABOUT AERO

Aero Industries, Inc. is a global leader in the manufacturing of trailer tarp systems and accessories. Founded in 1944, the company's heritage is rooted in engineering and innovation. Aero manufactures a complete line of American-made products for dumps, flatbeds, agriculture, refuse and other trailer applications.

INDIANAPOLIS, IN
800.535.9545

OMAHA, NE
800.535.8552

KENT, OH
888.237.2262

