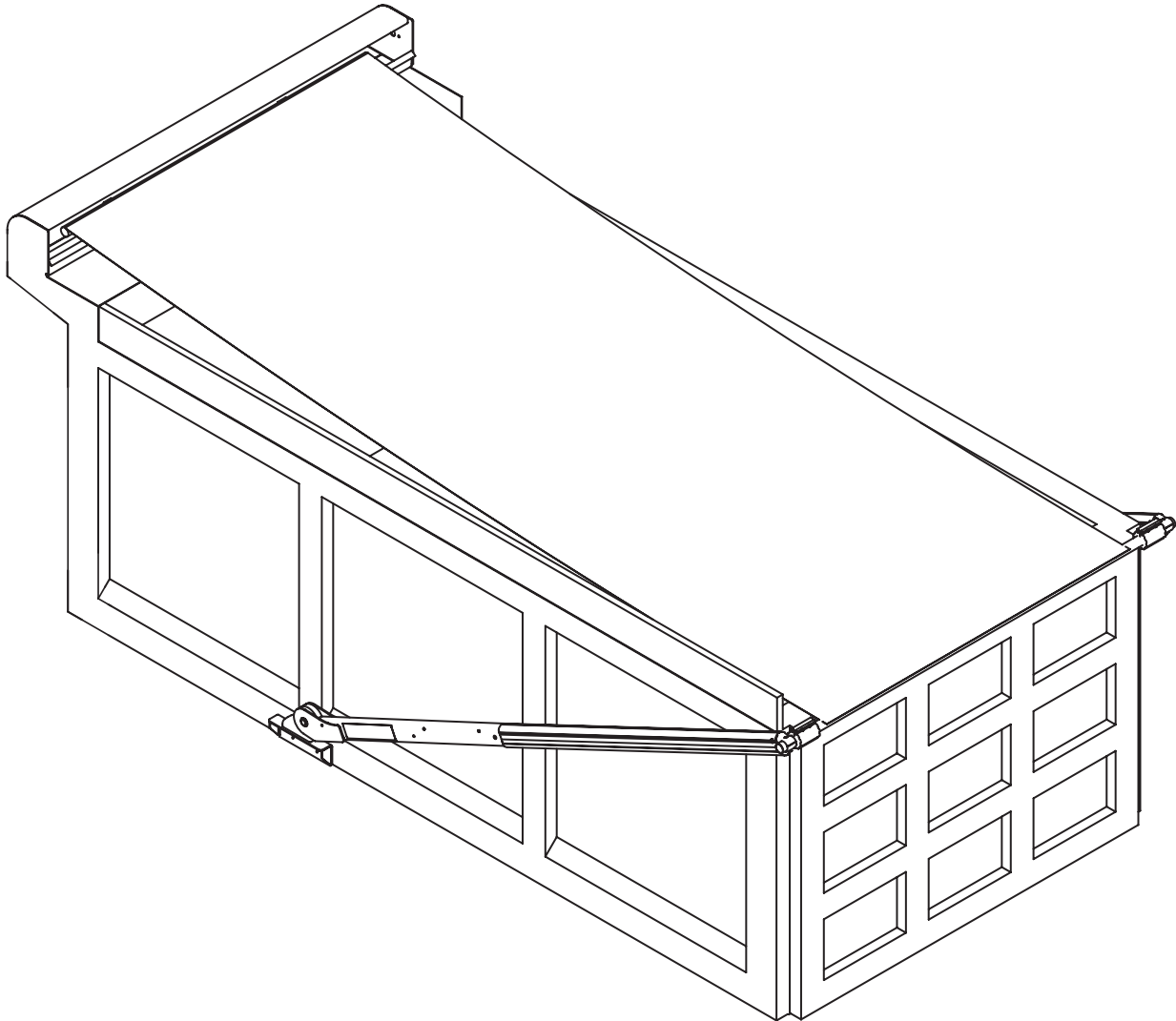




Serving the Truck & Trailer Industry  
Since 1944



## Installation Instructions

**Attention Dealers:** Please give this manual to the customer when product is delivered.

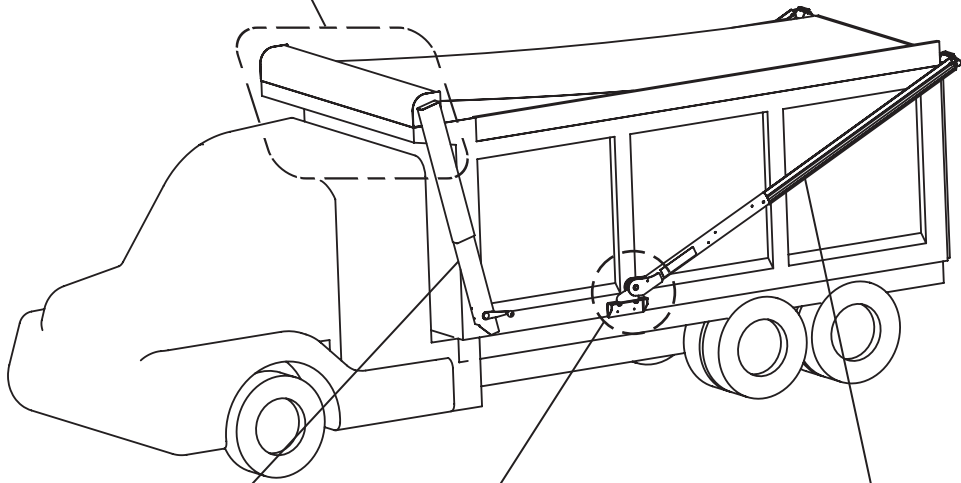
Call 800-535-9545 | [www.aeroindustries.com](http://www.aeroindustries.com)

Indianapolis, IN | Omaha, NE | Kent, OH | Valley, NE

## Installation Directory

Item	Step	Page
Safety Information	—	4
Warranty Information and Tools Required	—	5
End Plates, Wind Deflectors, and Tarp Housing		
Installing End Plates and Wind Deflector	1a	6
Installing Tarp Housing with Trailer Mounting Bracket	1b	7
Roll Up Bar		
Installing Manual Fixed Roll Up Bar	2a	8
Installing Electric Motor and Fixed Roll Up Bar	2b	9
Installing Manual Adjustable Roll Up Bar	2c	10
Installing Electric Motor and Adjustable Roll Up Bar	2d	11
Sprocket, Crank Assembly, Chain, and Chain Cover(s)		
Installing the Sprocket	3a	12
Installing Manual Crank Assembly	3b	12
Installing the Chain and Chain Cover(s)	3c	13
Electrical		
Installing the Standard Electrical Controls with Rocker Switch Truck	4a	14-15
Install and Wire Motor for Semi-trailer Truck	4b	16-17
Install Interior Cab Rocker Switch for Semi-trailer Truck	4c	18
Wiring Diagram for Lead & Pup with Contactors Mounted on Tractor	4d	19-20
Wiring Diagram for Lead & Pup with Contactors Mounted on Tractor	4e	21
Pivot Mounting Options	5	22-27
Installing Pivot Mounts (Near the Bottom Rail)	5a	23, 25-27
Installing Pivot Mounts (High Mount)	5b	24-27
Attach Tarp to Roll Up Bar		
Installing Tarp to Roll Up Bar, Roll Under (Standard)	6a	28
Installing Tarp to Roll Up Bar, Roll Over (Optional)	6b	28
AeroForce F2B Manual Model & Maintenance Recommendations	—	29

Wind Deflectors, Tarp Housings,  
End Plates, Brackets, and Roll Up Bars  
Pages 6-11



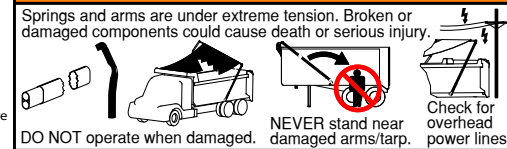

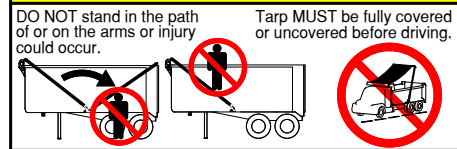
Crank Assemblies  
and Covers  
Pages 12-13

Lower Pivot  
Assemblies  
Page 23

Aluminum  
Arm Assemblies  
and Cross Arms  
Pages 25-27

## Safety Messages

- ⚠ WARNING:** Read this entire manual and all instructions before installation, operation, maintenance or repairs this product. Refer to the website for an explanation of safety labels and symbols.
- ⚠ WARNING:** Be sure that your working platform is secure. Use OSHA approved ladders or scaffolding to work above ground level.
- ⚠ WARNING:** Always wear safety glasses during installation and operation.
- ⚠ WARNING:** The AeroForce F2B arms move with the help of springs which must be properly released before any repairs. All spring tension must be properly released before any repairs. On website see “Properly Releasing Spring Tension” instruction before any repairs.
- ⚠ WARNING:** Springs and arms are under extreme tension. Broken or damaged components could cause death or serious injury. Follow instruction on releasing spring tension.
- ⚠ WARNING:** Never stand near damaged arms/tarp. Always check to make sure that no one is at the rear of the box or in the immediate area while repairing. Arms could come loose allowing the arm to rotate to the rear with tremendous force.
- ⚠ WARNING:** DO NOT operate when damaged. If the arms are damaged or fail to rotate freely under normal operation for any reason, discontinue use until repairs can be made.
- ⚠ WARNING:** Routinely inspect tarp and arms for wear and/or damage. Replace all worn or broken parts immediately.
- ⚠ WARNING:** Keep all clothing clear of moving parts.
- ⚠ WARNING:** Check for overhead power lines. Always check for overhead obstructions before covering and uncovering. DO NOT operate under low hung power lines.
- ⚠ CAUTION:** Tarp MUST be fully covered or uncovered before driving. If it is not, could result in being over height and risk of hitting overhead obstructions.
- ⚠ CAUTION:** DO NOT stand in the path of or on the arms, or injury could occur.

<b>MAINTENANCE INSTRUCTIONS</b> <ul style="list-style-type: none"> <li>* Refer to Maintenance sheet or website.</li> <li>* Repairs must ONLY be made after proper instruction.</li> <li>* Spring tension must be properly released before repairs.</li> <li>* Replace damaged or broken parts.</li> <li>* Keep path of arms clear.</li> </ul>	<b>⚠ WARNING</b> Springs and arms are under extreme tension. Broken or damaged components could cause death or serious injury.  DO NOT operate when damaged. NEVER stand near damaged arms/tarp. Check for overhead power lines.	1-800-535-9545 	<b>⚠ CAUTION</b> DO NOT stand in the path of or on the arms or injury could occur. Tarp MUST be fully covered or uncovered before driving.  <b>⚠ CAUTION</b>	<b>OPERATION INSTRUCTIONS</b> <ul style="list-style-type: none"> <li>* Refer to Operations sheet or website.</li> <li>* Face vehicle into the wind.</li> <li>* Only drive with tarp in fully covered or uncovered position.</li> <li>* Routinely inspect tarp and arms and replace if damaged.</li> </ul>
www.easycovermaintenance.com	AEROFORCE	Label part# 0920-039003	AEROFORCE	www.easycoveroperation.com

## Explanation of Signal Words

- ⚠ WARNING:** Indicates a hazardous situation which, if not avoided, could result in death or serious injury.
- ⚠ CAUTION:** Indicates a hazardous situation which, if not avoided, could result in minor or moderate injury.
- NOTICE:** Risk of product or vehicle being damaged.

This manual explains how to install and maintain the AeroForce F2B tarping system.

**Customer:** If you have any concerns or questions prior to the installation of this product, please call our Customer Service at 1-800-535-9545.

Tools Required for Installation
---------------------------------

Marker or Felt Pen Tape Measure Black Electrical Tape Crimping Tool Awl Hammer 1 1/8" hole saw Drill Bits: .257" (F drill), 9/32", .316" (O drill), 13/32", 17/32" Sockets: 5/16", 7/16", 1/2", 9/16", 1-1/8" Open End or Box Wrenches: 7/16", 1/2", 9/16", 3/4", 1-1/8" Vice Grip Pliers (2 pair) Electric or Air Drill Philips Screw Drivers (small and large) Allen Wrench Set
--

## Step 1a

### Installing End Plates and Wind Deflector

**NOTE:** On manual crank installations before installing the end plates, visually check the path from the mounting plate to the crank assembly. Make sure when the chain cover is assembled it does not obstruct the door or create a hazard to the operator.

**NOTE:** If end plate does not set squarely against the top rail, use shims to square the plate. Shim material is not included in assembly package.

Index	Description	Qty	Index	Description	Qty
1	End Plates (DS & PS)	2	4	3/8-16 x 1 Hex Bolt	6
2	Wind Deflector	1	5	3/8-16 Nylon Hex Nut	10
3	3/8-16 x 1 Carriage Bolts	4			

1) **Figure 6-1.** Install 3/8-16 x 1 carriage bolts (3) and 3/8-16 Nylon hex nuts (4) in the driver's side and passenger's mounting plates (1). Do not tighten.

2) Slide end plates (1) into wind deflector's extrusion. Do not tighten.

3) Carefully place assembly onto the cab shield or top rail and position at the farthest point forward. This will keep the air from coming in under the wind deflector (2) to a minimum.

3) **Figure 6-2.** Move the end plates inward until they are against the cab shield or top rail. Lift rear of assembly until the aligning notch is even with the top rail. Clamp driver's side end plate into place.

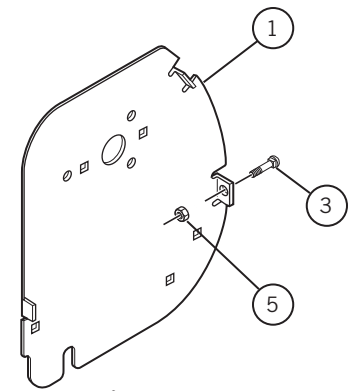
4) Using the end plate as a template, drill three 13/32" holes through the top rail where square holes reside.

5) Secure driver's side end plate with 3/8-16 x 1 hex bolt (5), 3/8 lock washer (6), and 3/8-16 Nylon hex nut (7).

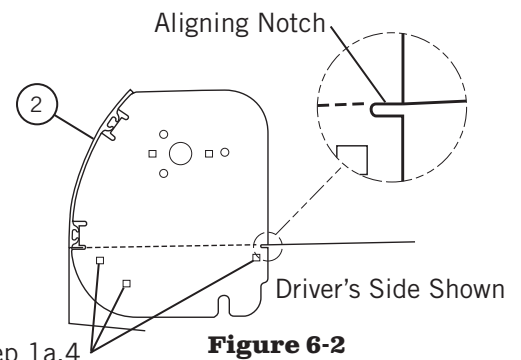
6) Repeat **Steps 1a.4–1a.5** for passenger's side end plate (1).

7) Tighten nuts on carriage bolts holding the wind deflector (2).

**▲ IMPORTANT:** DO NOT allow any gap below the wind deflector. This can cause the tarp to sail and let the cross arm slam down causing damage.



**Figure 6-1**



**Figure 6-2**

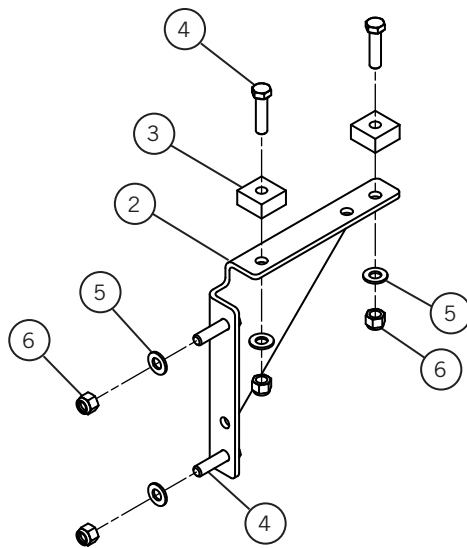
## Step 1b

### Installing Tarp Housing with Trailer Mounting Bracket

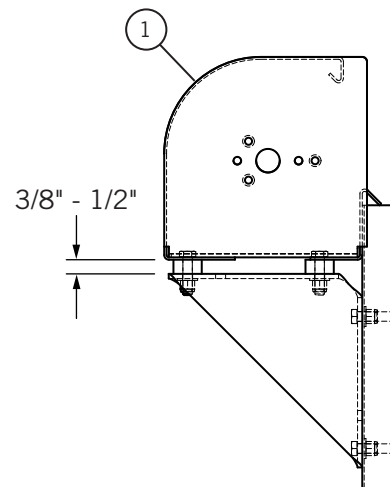
**NOTE:** On manual crank installations before installing the mounting plates, visually check the path from the mounting plate to the crank assembly. Make sure when the chain cover is assembled it does not obstruct the door or create a hazard to the operator.

Index	Description	Qty	Index	Description	Qty
1	Tarp Housing	1	4	1/2-13 x 2 Hex Bolt GR5	8
2	Mounting Bracket Trailer	2	5	1/2 Flat Washer	8
3	Rubber Bushing	4	6	1/2-13 Nylon Hex Nut	8

- 1) Figure 7-2.** Turn tarp housing (1) upside down and position mounting bracket (2) 12" in from each end and flush with the back of the tarp housing (1) (not the end plates). Keeping brackets straight and parallel with end plates, mark holes through brackets
- 2) Drill marked holes using 17/32" drill bit.
- 3) Figure 7-1.** Attach mounting brackets with rubber bushings (3), 1/2-13 x 2 hex bolt (4), 1/2 flat washer (5), and 1/2-13 nylon hex nut (6). Tighten until bushings compress to approximately 3/8" to 1/2".
- 4) Figure 7-2.** Hold housing up to trailer firmly, center on trailer and trace holes in mounting brackets. Drill marked holes using 17/32" drill bit.
- 5) Attach with 1/2-13 x 2 hex bolt (4), 1/2 flat washer (5), and 1/2-13 nylon hex nut (6).



**Figure 7-1**



**Figure 7-2**

## Step 2a

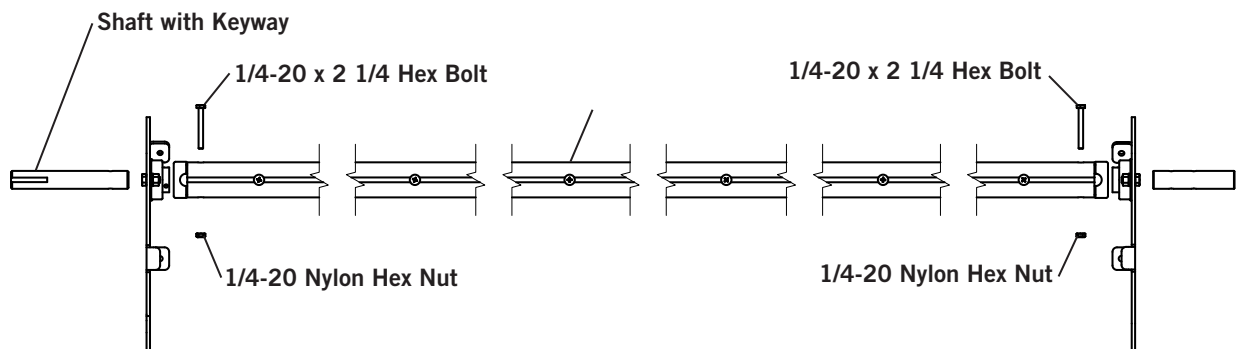
### Installing Manual Fixed Roll Up Bar

Index	Description	Qty
1	Fixed Manual Roll Up Bar	1

- 1) **Figure 8-1.** Unbolt and remove the shafts from both ends of fixed manual roll up bar (1).
- 2) On the driver's side align the fixed manual roll up bar (1) with the bearing, insert the shaft with the keyway through the bearing.
- 3) Bolt the shaft using the 1/4-20 x 2 1/4 hex bolt and 1/4-20 nylon hex nut removed in **Step 2a.1**.
- 4) On the passenger's side align the fixed manual roll up bar (1) with the bearing and insert shaft through the bearing.

**NOTE:** Make sure there is clearance on the outside of end plate of tarp housing to allow shaft to stick out far enough.

- 5) Bolt the shaft using the 1/4-20 x 2 1/4 hex bolt and 1/4-20 nylon hex nut removed in **Step 2a.1**.



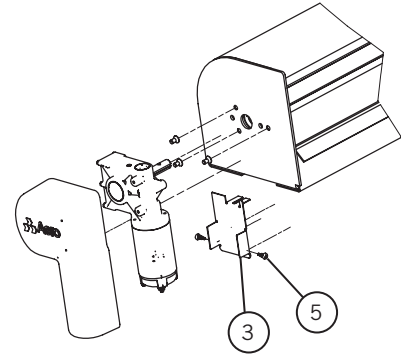
**Figure 8-1**



## Step 2b

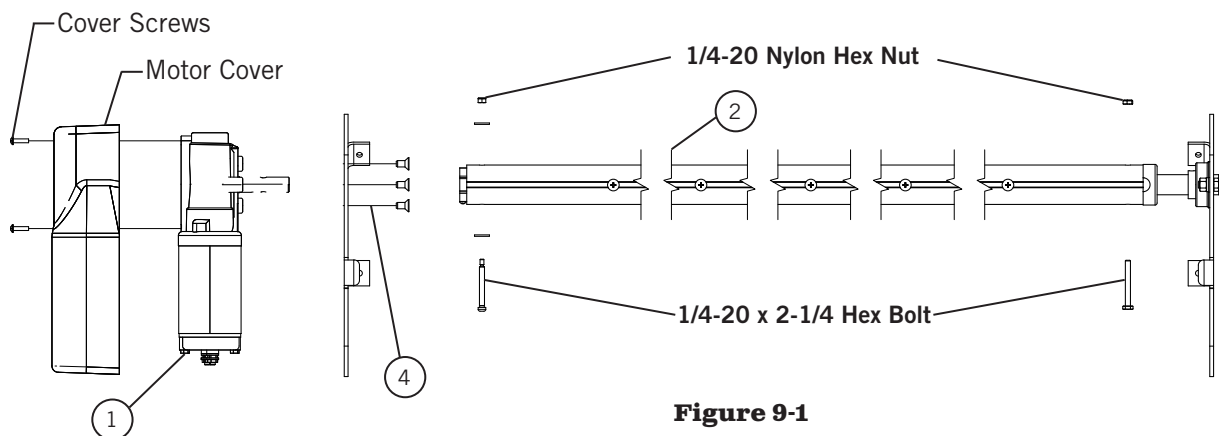
### Installing Electric Motor and Fixed Roll Up Bar

Index	Description	Qty
1	Motor RA/SWB	1
2	Fixed Electric Roll Up Bar	1
3	Motor Cover	2
4	5/16-18 x 7/8 FHCS	3
5	#10 x 1 Self-drilling Pan Head	2



**Figure 9-2**

- Figure 9-1.** Fasten motor RA/SWB (1) to the end plate of tarp housing with three 5/16-18 x 7/8 FHCS (3).
  - With screws provided, attach the cover to the motor. (Cover will need to be removed for wiring.)
  - Figure 9-2.** When installing on a tarp housing use the motor cover (3) with two #10 x 1 self-drilling pan head screws (5).
  - Figure 9-1.** Unbolt and remove the shaft from end of fixed electric roll up bar (1).
  - One end does not have a shaft. Remove the nut and bolt from that end. Insert end onto shaft of motor RA/SWB (1), line up hole in roll up tube with hole in motor shaft, and with previously removed nut and bolt secure roll up bar to shaft.
  - On the opposite end line up the fixed electric roll up bar (2) with the bearing and insert shaft through the bearing.
- NOTE:** Make sure there is clearance on the outside of end plate of tarp housing to allow shaft to stick out far enough.
- Bolt the shaft using the 1/4-20 x 2 1/4 hex bolt and 1/4-20 nylon hex nut removed in **Step 2b.4**.



**Figure 9-1**

## Step 2c

### Installing Manual Adjustable Roll Up Bar

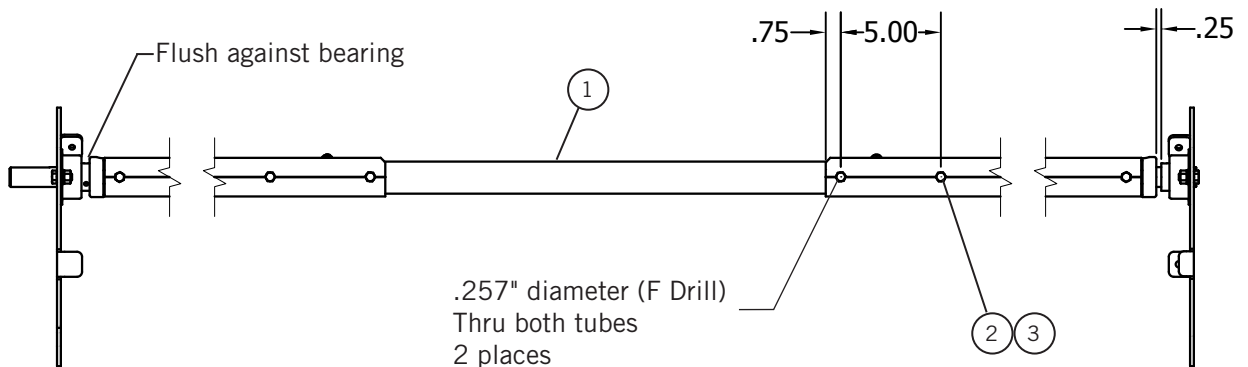
**NOTE:** Hardware pack is taped to roll up bar.

Index	Description	Qty
1	Adjustable Manual Roll Up Bar	1
2	1/4-20 x 2 1/4 Hex Bolt	2
3	1/4-20 Nylon Hex Nut	2

- 1) Remove hardware package and tape from center of adjustable manual roll up bar, one end is loose and can slide off. Place hardware package to the side.
- 2) One end of adjustable manual roll up bar has a shaft with a hole, insert this end through the bearing on the driver's end of tarp housing.
- 3) Make sure driver's end of roll up bar is against bearing. Extend other end of roll up bar out and insert shaft through the bearing on the passenger's end of tarp housing.

**NOTE:** Make sure there is clearance on the outside of tarp housing to allow shaft to stick out far enough.

- 4) **Figure 10-1.** With passenger's end of roll up bar within 1/4" - 1/2" of bearing drill two .257" (F drill) holes thru both tubes as shown.
- 5) Secure outside tube to inside tube with two Tek screws from hardware pack.



**Figure 10-1**

## Step 2d

### Installing Electric Motor and Adjustable Roll Up Bar

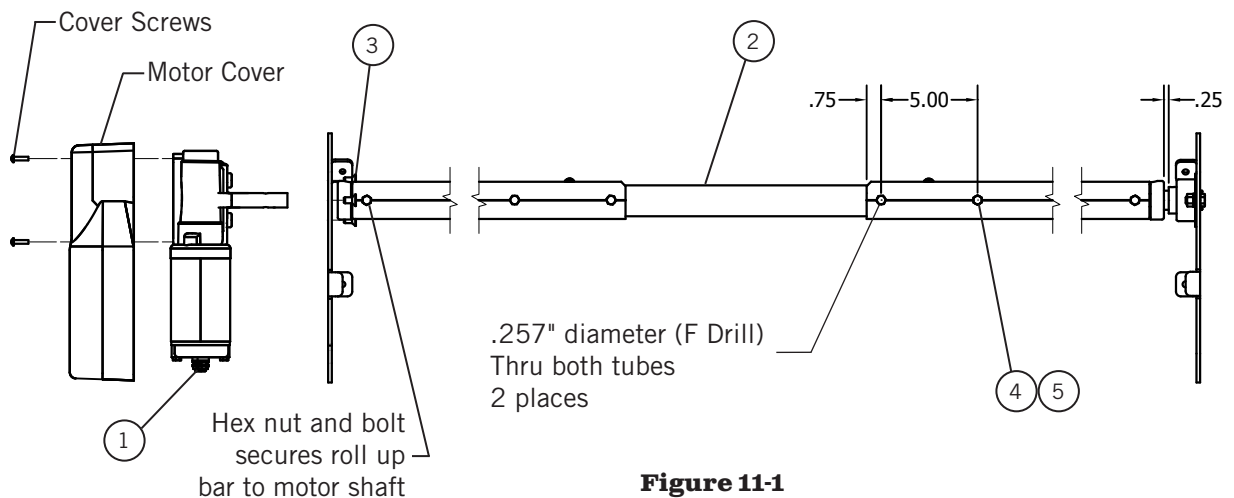
**NOTE:** Use hardware pack taped to roll up bar.

Index	Description	Qty
1	Motor Winch "B"	1
2	Adjustable Electric Roll Up Bar	1
3	5/16-18 x 5/8 FHCS	3
4	1/4-20 x 2 1/4 Hex Bolt	2
5	1/4-20 Nylon Hex Nut	2

- 1) **Figure 11-1.** Fasten Motor Winch "B" (1) to driver's side end plate with 5/16-18 x 5/8 FHCS (3).
- 2) With screws provide with the motor attach the cover to the motor. (Cover will need to be removed for wiring.)
- 3) Remove hardware package and tape from center of adjustable electric roll up bar (2), one end is loose and can slide off. Place hardware package to the side.
- 4) One end does not have a shaft. Remove the nut and bolt from that end. Insert end onto shaft of motor winch "B", line up hole in roll up bar with hole in motor shaft, and with previously removed nut and bolt secure roll up bar to shaft.
- 5) Extend other end of roll up bar out and insert shaft through the bearing on the passenger's end of tarp housing.

**NOTE:** Make sure there is clearance on the outside of tarp housing to allow shaft to stick out far enough.

- 6) With passenger's end of roll up bar within 1/4" - 1/2" of bearing drill two .257" (F drill) holes thru both tubes as shown.
- 7) Secure outside tube to inside tube with two 1/4 x 2 1/4 Hex Bolts from hardware pack.



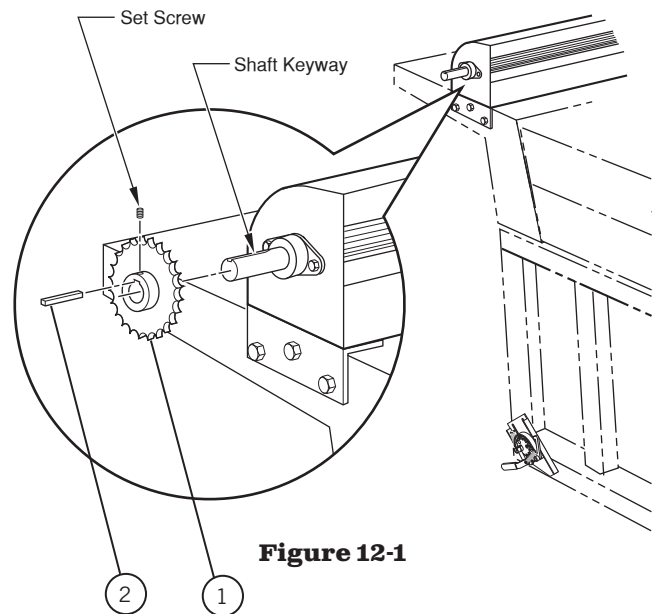
**Figure 11-1**

## Step 3a

### Installing the Sprocket

Index	Description	Qty
1	Sprocket	1
2	Key	1

- 1) **Figure 12-1.** Slide the sprocket (1) over the outside of the shaft of the driver's side roll up bar. Position sprocket so that it aligns with the crank assembly sprocket.
- 2) Lightly tap the key (2) into the shaft keyway.
- 3) Tighten the Allen set screw on the sprocket until it begins to feel tight. Make sure the screw engages the key (2). Do not over tighten.



**Figure 12-1**

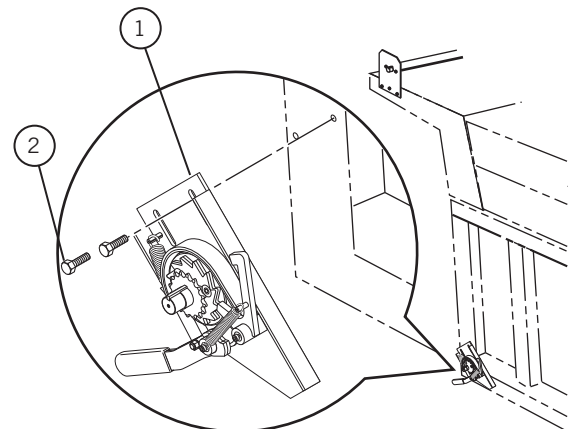
## Step 3b

### Installing Manual Crank Assembly

Index	Description	Qty
1	Crank Assembly	1
2	3/8 x 1 Self Tapping Hex Bolt	2

**NOTE:** If you need to mount in a space where you cannot use bolts and nuts, use self-tapping bolts and lock washers. Not included in the package.

- 1) Remove the cover (if installed) on the crank assembly and lay cover aside until after the chain is installed.
- 2) **Figure 12-2.** Place the crank assembly at or near the bottom front corner of the box on the driver's side. Rotate the crank assembly so that it angles toward the tarp roll up bar.
- 3) Mark the mounting holes on the box. Drill marked holes using 13/32" drill bit.
- 4) Fasten the crank assembly to the box with bolts, washers, and nuts. Make sure to bolt the assembly in the highest upward position.



**Figure 12-2**

## Step 3c

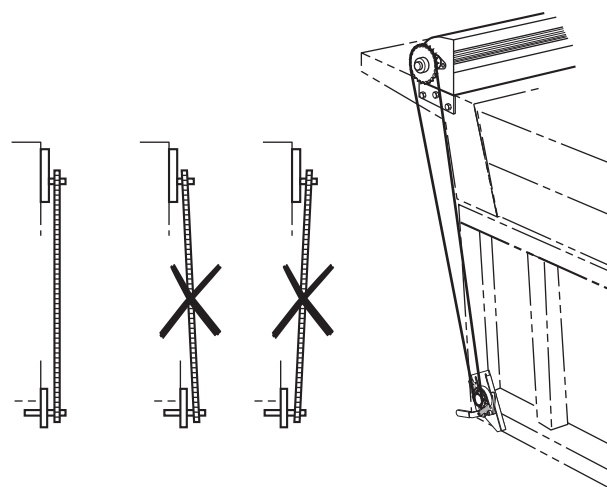
### Installing the Chain and Chain Cover(s)

Index	Description	Qty	Index	Description	Qty
1	Chain	1	5	Guard Mounting Brackets	6
2	Master Link	1	6	#14 x 1/2 Self Drilling Screw	6
3	Crank Cover Aluminum	1	7	#14 x 1 Self Drilling Screw	6
4	Chain Cover Lower Aluminum	1	8	Crank Handle	1

1) **Figure 13-1.** Wrap chain (1) around both sprockets and remove the excess links.

2) Wrap the shortened chain around the sprockets and fasten the two ends with the master link (2).

**NOTE:** To remove any slack in the chain, loosen the crank assembly mounting bolts and slide the crank assembly away from the tarp roll up bar. The chain should be snug but not overly tight. Retighten the Mounting bolts.



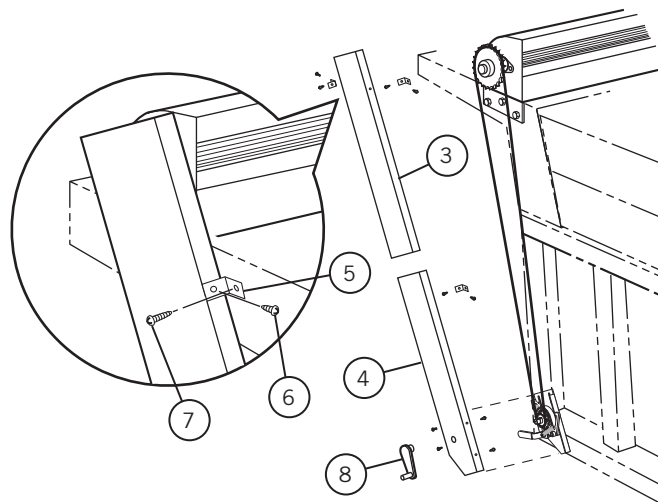
**Figure 13-1**

### Aluminum Cover

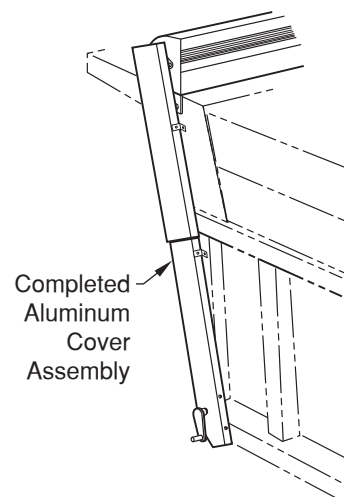
3) **Figure 13-2.** Install crank cover lower aluminum (4) with the guard mounting brackets (5) to the body with #14 x 1/2 self drilling screws (6) and #14 x 1 self drilling screw (7).

4) **Figure 13-3.** Position the chain cover aluminum (3) so that it lays over the top edge of crank cover lower aluminum (4). Adjust the chain cover aluminum (3) so that it clears the chain and sprocket evenly on both sides and clears the top by 1".

**NOTE:** The crank handle is used to move the tarp forward. The crank handle should be removed once the tarp is properly positioned.



**Aluminum Cover**  
**Figure 13-2**



**Figure 13-3**

### Step 4a

Installing the Standard Electrical Controls with Rocker Switch Truck

**NOTE:** Use hardware pack Motor Kit #0311-963317 & Tractor Kit #0311-963318

Wire **NOT** included in kit.

Index	Description	Qty	Index	Description	Qty
1	Reverse DC Contactor	1	12	10-32 Hex Nut	2
2	DC Contactor Cover	1	13	1/4 x 3/4 Pan Head Phillips	12
3	Switch Rocker Assy for DC Contactor	1	14	1/4-20 x 1 Hex Head Bolt	2
4	Circuit Breaker 50 Amp	1	15	1/4-20 x 2 Hex Head Bolt	2
*5	Wire #6 Duplex	Varies	16	1/4 Flat Washer	8
*6	Wire #14ga 3 Conductor Type SJ	20'	17	1/4-20 Nylon Hex Jam Nut	4
7	Wire End #6 x 1/4 Ring Term.	2	18	5/16-24 Hex Nut	4
8	Wire End #6 x 3/8 Ring Term.	5	19	5/16 Lock Washer	4
9	Wire End #6 x #10 Screw Ring Terminal	2	20	Clamp Metal Loom Plastic Coated	12
10	Wire End #14 x 1/4 Push on	6	21	Wiring Diagram Reverse Contactor	1
11	Wire End #14 x 3/8 Ring Term.	1			

**▲ IMPORTANT: Switch is not rated for outdoor use.**

- 1) Open and layout all electric hardware parts.
- 2) Find a convenient place on the driver's side under the dashboard to mount the rocker switch. Using the switch as a template, mark and drill two 9/32" holes.
- 3) Mount rocker switch (3) using (2) 1/4-20 x 1 Hex bolts (14), (4) 1/4 flat washers (16), and (2) 1/4 Nylon hex nuts (17).
- 4) Find a secure location at or near the back of the cab to mount the reversing DC contactor (1). Mount the reversing DC contactor (1) using (2) 1/4-20 x 2 hex bolts (15), (4) 1/4 flat washers (16), and (2) 1/4 - 20 Nylon hex nuts (17). Do not tighten at this time.
- 5) Measure the wiring distance from the gearmotor to the pivot box, then from the pivot point through the truck body to the DC contactor in the cab.

**▲ CAUTION:** Incorrect wiring can cause failure to the AeroForce F2B system and possible harm to the operator.

\* #6 Duplex Wire and #14 wire are not supplied in this kit, depending on kit ordered.

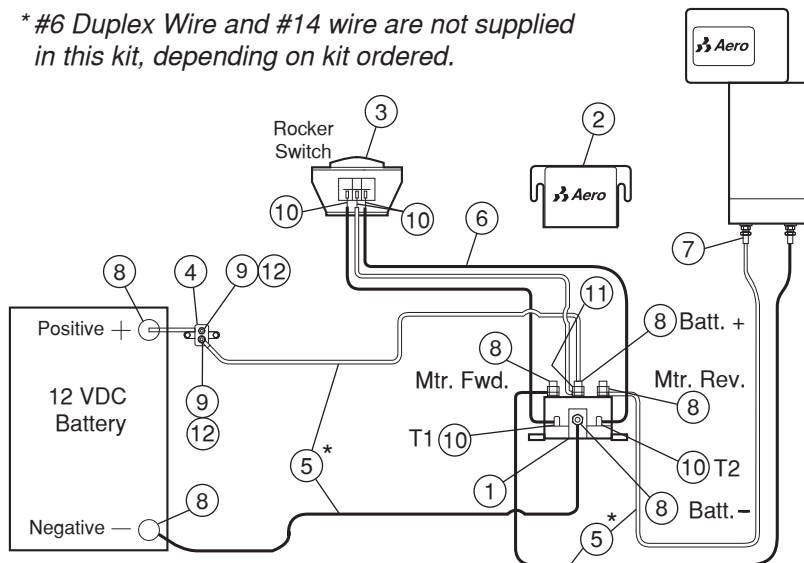
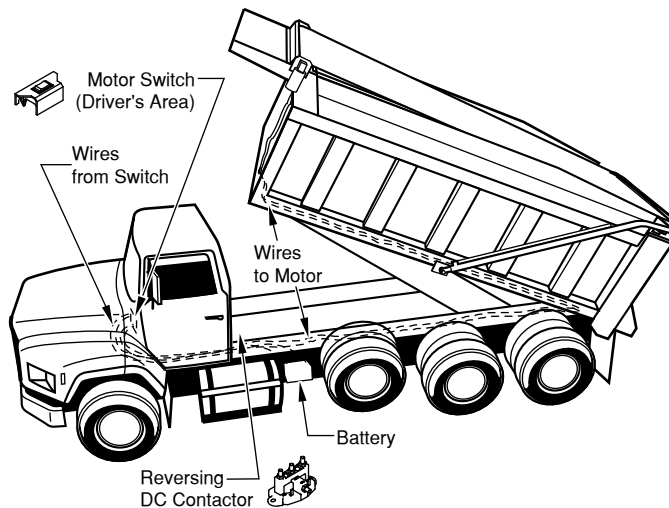


Figure 14-1

## Step 4a (cont.)

- 6) Secure the #6 wire (5) along the vehicle frame using clamp metal looms (20) and 1/4 x 3/4 pan head Phillips (13) being sure to avoid any exhaust, moving parts, or sharp edges that could damage the wire's protective coating. The wire should have a loop at the hinge point where the bed pivots on the frame. A good rule of thumb is to match the loop of factory installed wires and lines or hoses. This will allow sufficient flex during bed cycling operation. Insufficient or improper loop can result in wire damage when the bed is raised.
  - 7) Measure distance between rocker switch (3) and reverse DC contactor (1). Wire switch (3) and reversing DC contactor (1) according to diagram with #14 wire (6).
  - 8) Measure distance between battery and reverse DC contactor (1) run #6 wire (5) between the two.
  - 9) Install a circuit breaker (4) at or very near the battery's positive terminal. Secure circuit breaker in place with a zip tie if possible to prevent movement.
  - 10) Place the DC contactor cover (2) on the reversing DC contactor (1) and tighten the 1/4-20 bolts and nuts.
- NOTICE:** Circuit breaker must be properly installed or motor warranty is void.



**Figure 15-1**

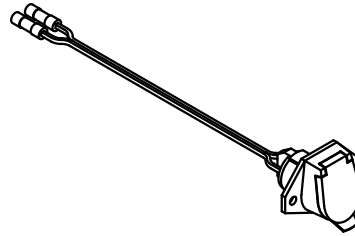


## Step 4b

### Install and Wire Motor for Semi-trailer Truck

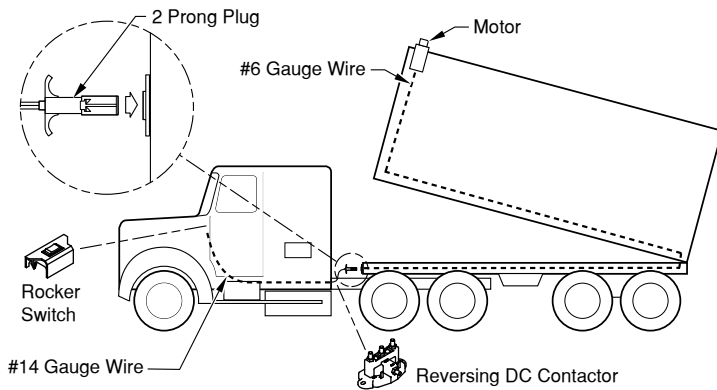
**NOTE:** Use hardware pack Motor Kit #0311-963317

- 1) Install receptacle at the front of the trailer. Attach the #6 wire to the butt connectors on the receptacle.



#### For End Dumps

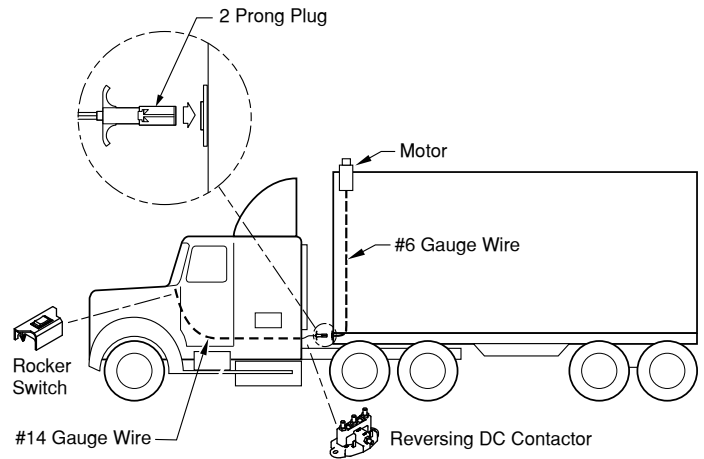
- 2a) **Figure 16-1.** Run #6 wire from receptacle to rear of trailer, onto dump bed, back to the front of the trailer and up to the motor. Secure all wire with clamps.



**Figure 16-1**

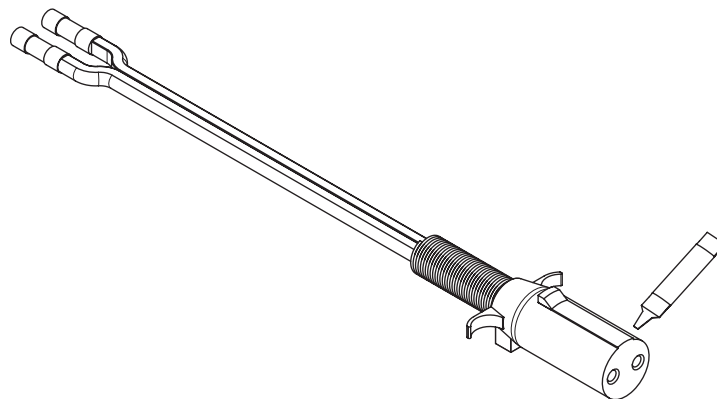
#### For Bottom Dumps

- 2b) **Figure 16-2.** Run #6 wire from receptacle up to the motor. Secure all wire with clamps.



**Figure 16-2**

**NOTICE:** Apply conductive grease to all 2 Prong Plug connections.



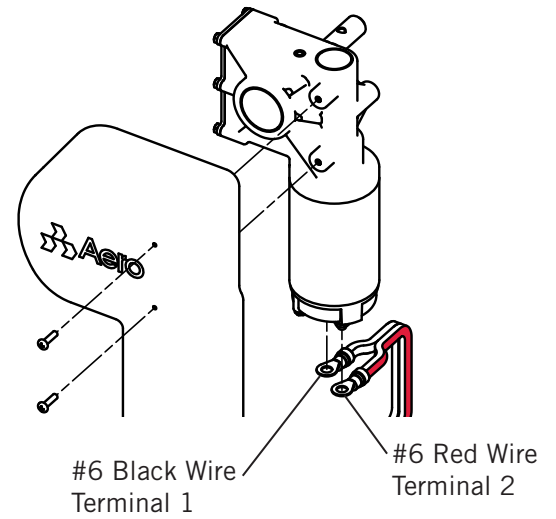
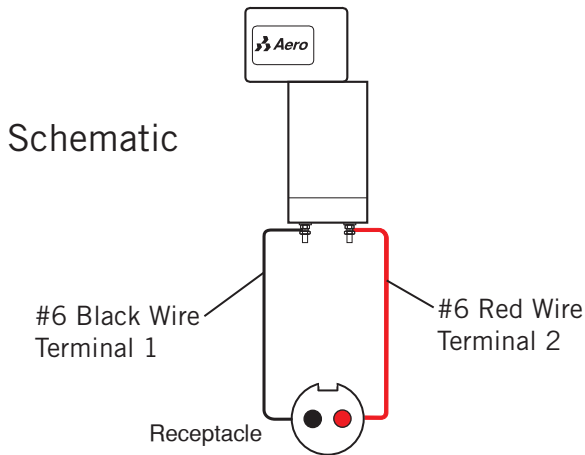


**Step 4b** (cont.)

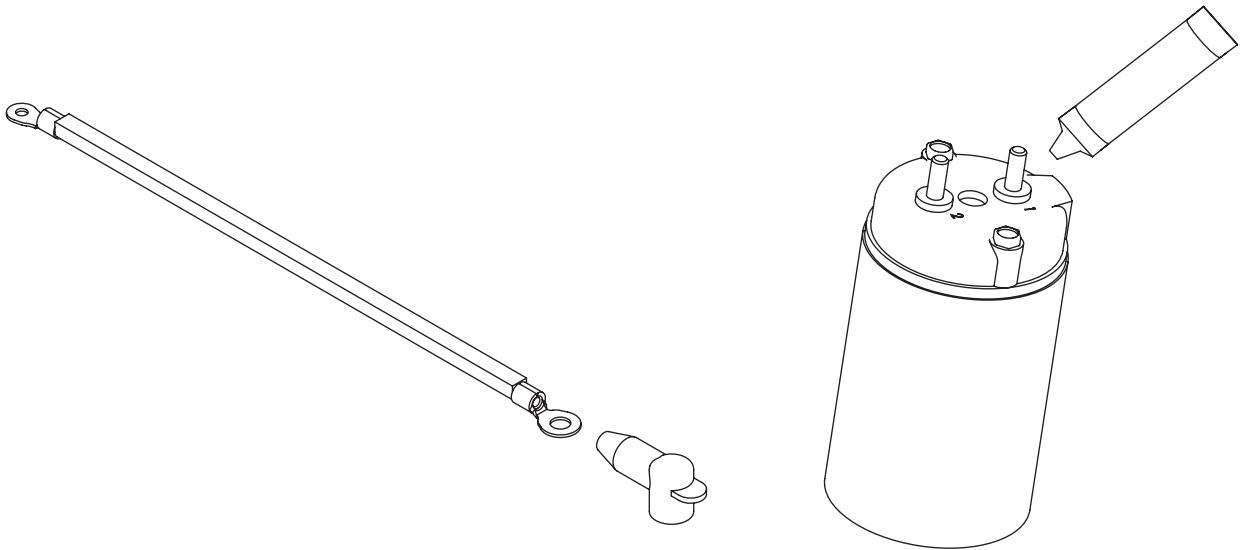
Install and Wire Motor for Semi-trailer Truck

**NOTE:** Use hardware pack Motor Kit #0311-963317

3) Attach #6 wire to motor with 1/4 ring terminals.



**NOTICE:** Install boot caps and apply dielectric grease to all ring terminal connections.



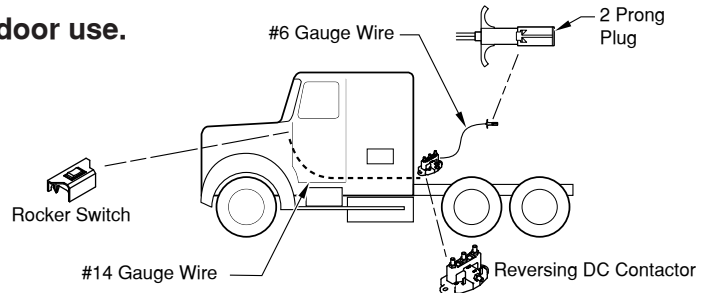
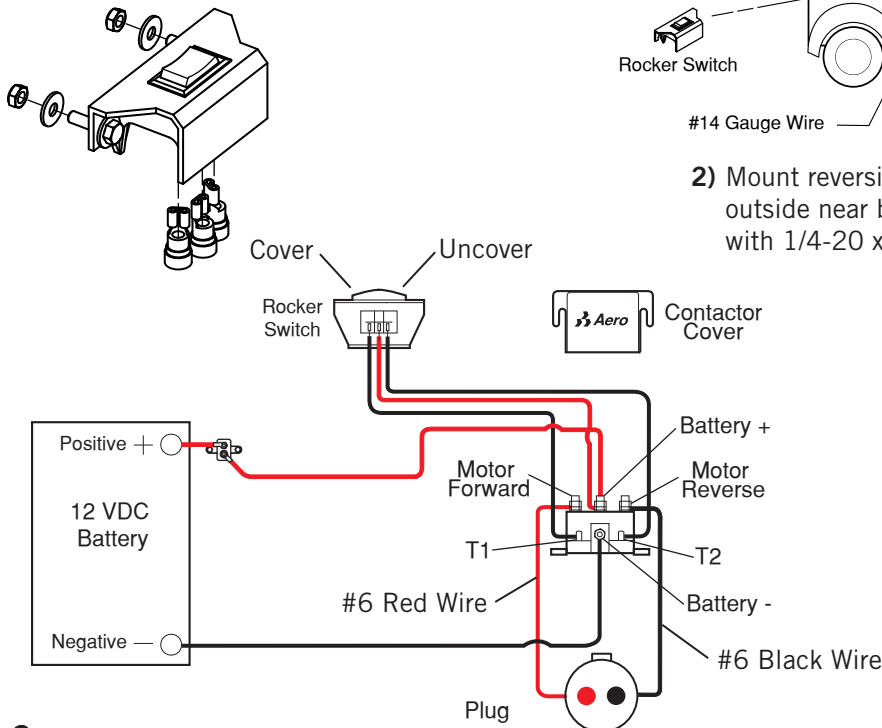
## Step 4c

### Install Interior Cab Rocker Switch for Semi-trailer Truck

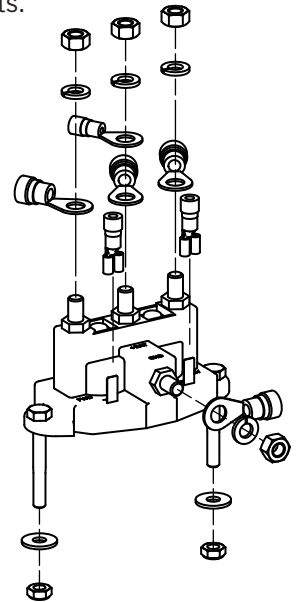
**NOTE:** Use Tractor Kit #0311-963318 (#6 wire not in kit)  
Locate Operation/Maintenance Sheet and keep near switch.

**IMPORTANT:** Switch is not rated for outdoor use.

- 1) Find a convenient place on the driver's side under the dashboard to mount the rocker switch with 1/4-20 x 1" hex bolts

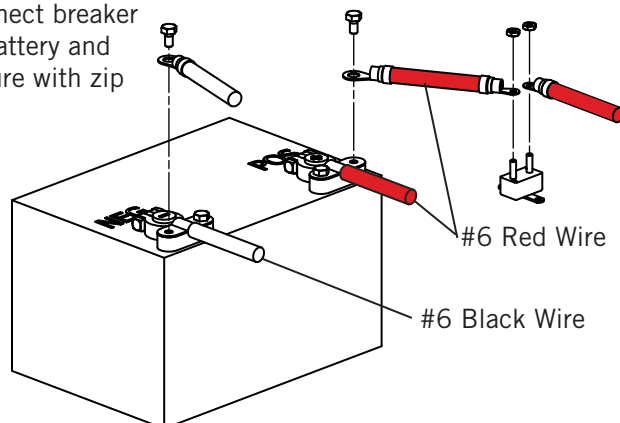


- 2) Mount reversing contactor outside near back of cab with 1/4-20 x 2" hex bolts.



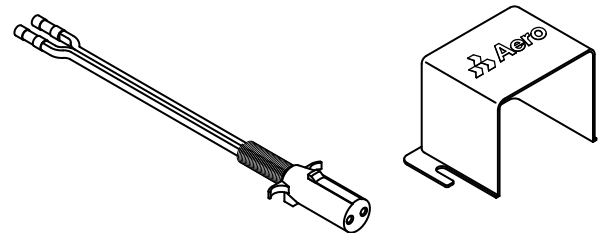
- 3) Run wire from switch to reversing contactor. Run wire from battery to reversing contactor. Secure all wire with clamps.

- 4) Connect breaker to battery and secure with zip ties.



- 5) Connect receptacle to reversing contactor. Make sure to have enough wire to be able to plug into trailer.

- 6) Place cover on reversing contactor.

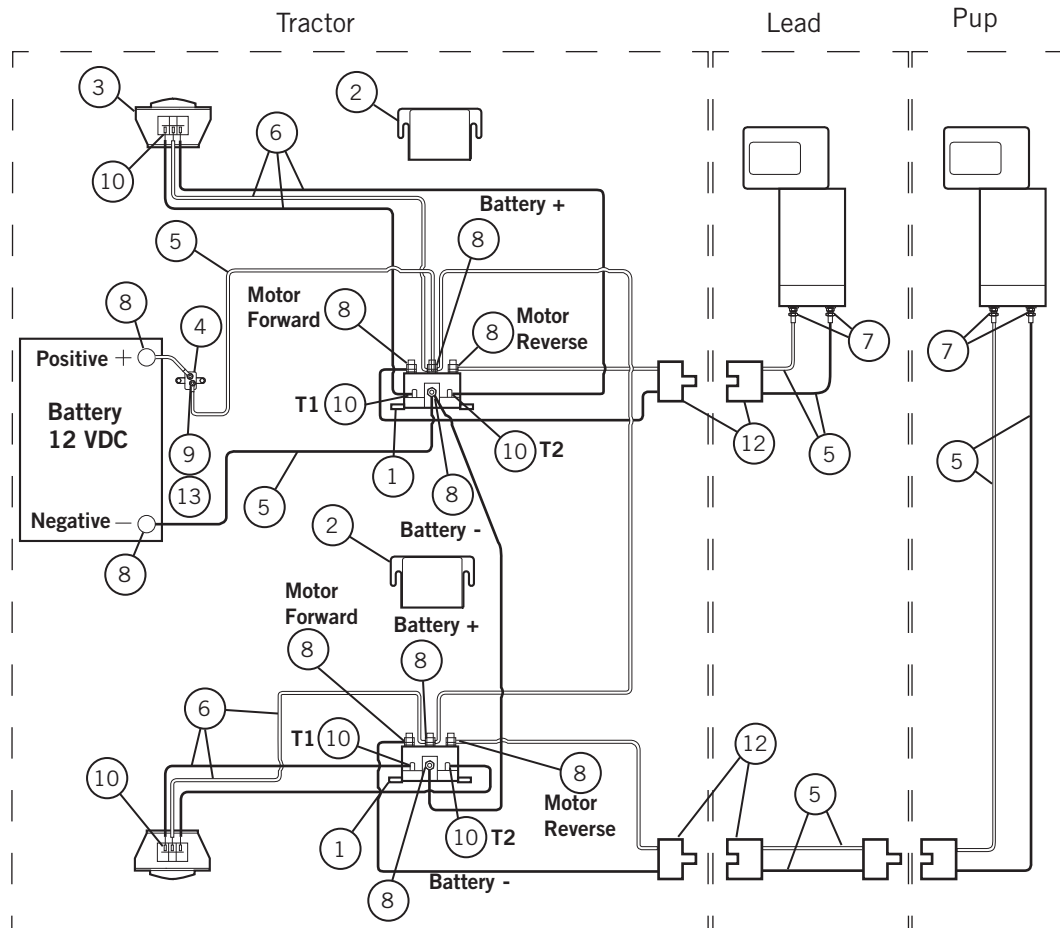


- 7) Test switch to see if system operates correct direction. If not reverse the wires on the motor and retest.

## Step 4d

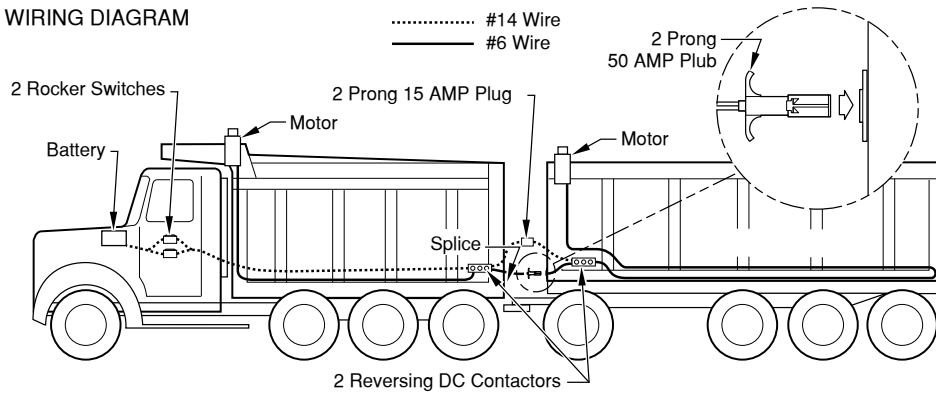
### Wiring Diagram for Lead & Pup with Contactors Mounted on Tractor

Index	Description	Qty	Index	Description	Qty
1	Reverse DC Contactor	2	11	Wire End #14 x 3/8 Ring Term.	2
2	DC Contactor Cover	2	12	Plug Quick Disconnect Assembly	2
3	Switch Rocker Assy for DC Contactor	2	13	10-32 Hex Nut	2
4	Circuit Breaker 50 Amp	1	14	1/4-20 x 1 Hex Head Bolt	4
5	Wire #6 Duplex	Varies	15	1/4-20 x 2 Hex Head Bolt	4
6	Wire #14ga 3 Conductor Type SJ	20'	16	1/4 Flat Washer	16
7	Wire End #6 x 1/4 Ring Terminal	4	17	1/4-20 Nylon Hex Jam Nut	8
8	Wire End #6 x 3/8 Ring Terminal	10	18	5/16-24 Hex Nut	8
9	Wire End #6 x #10 Ring Terminal	2	19	5/16 Lock Washer	8
10	Wire End #14 x 1/4 Push on	10	20	Wiring Diagram Reverse Contactor	1

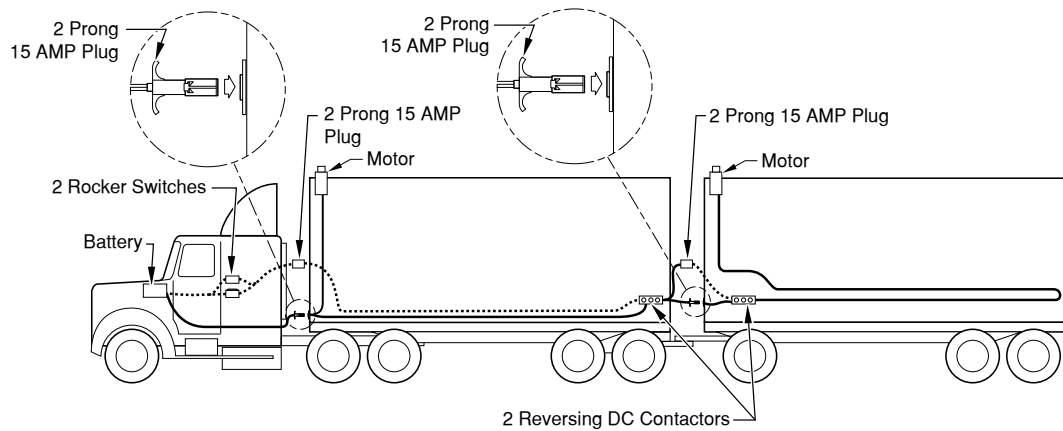


**Step 4d** (cont.)

SHORT DOUBLE WIRING DIAGRAM



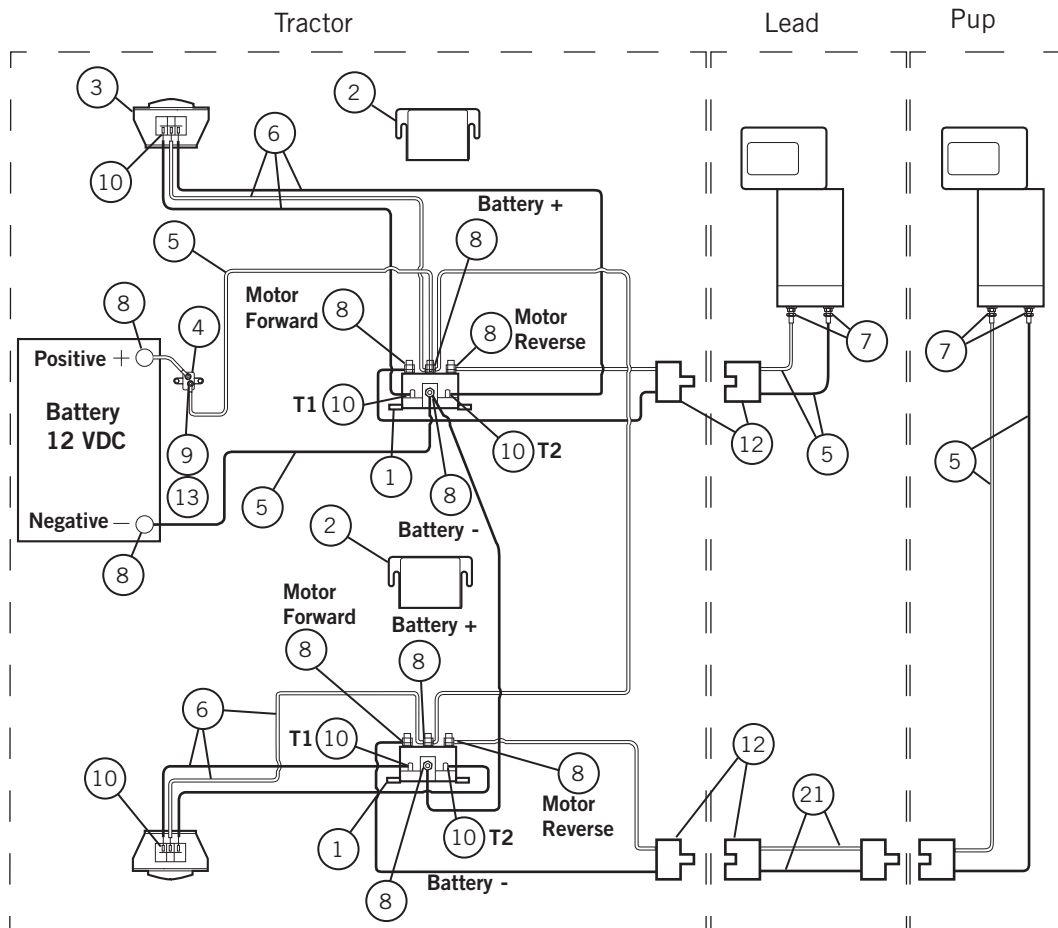
LEAD & PUP WIRING DIAGRAM



## Step 4e

### Wiring Diagram for Lead & Pup with Contactors Mounted on Tractor

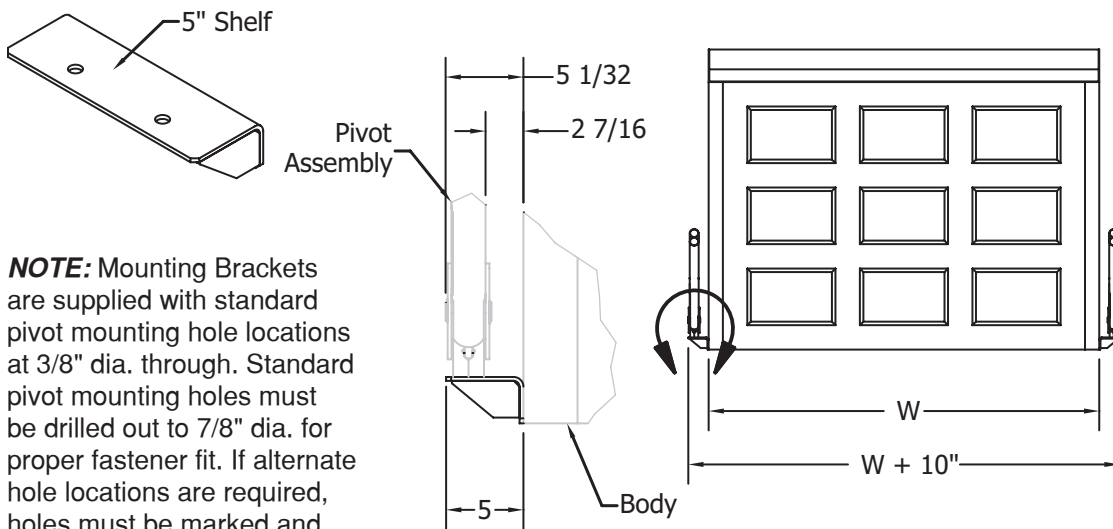
Index	Description	Qty	Index	Description	Qty
1	Reverse DC Contactor	2	11	Wire End #14 x 3/8 Ring Term.	2
2	DC Contactor Cover	2	12	Plug Quick Disconnect Assembly	2
3	Switch Rocker Assy for DC Contactor	2	13	10-32 Hex Nut	2
4	Circuit Breaker 40 Amp	1	14	1/4-20 x 1 Hex Head Bolt	4
5	Wire #6 Duplex	Varies	15	1/4-20 x 2 Hex Head Bolt	4
6	Wire #14ga 3 Conductor Type SJ	20'	16	1/4 Flat Washer	16
7	Wire End #6 x 1/4 Ring Terminal	4	17	1/4-20 Nylon Hex Jam Nut	8
8	Wire End #6 x 3/8 Ring Terminal	10	18	5/16-24 Hex Nut	8
9	Wire End #6 x #10 Ring Terminal	2	19	5/16 Lock Washer	8
10	Wire End #14 x 1/4 Push on	10	20	Wiring Diagram Reverse Contactor	1
			21	Wire #4 Duplex	Varies



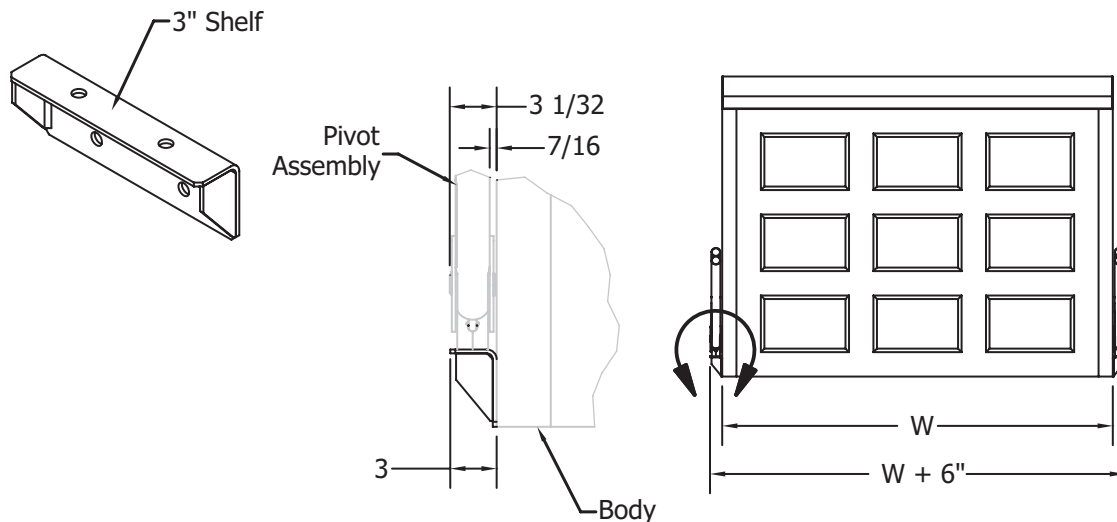
## Step 5

### Pivot Mounting Options

Before installing any mounting brackets, you need to decide how you want the brackets to be mounted. Because the mounting brackets are universal they can be mounted one of two ways: 1) with a 5" shelf, or 2) with a 3" shelf. This gives you some options to help you work around any obstacles that may exist on the truck body. By rotating the bracket you can create a wide profile or a narrow profile.



**Figure 22-1**

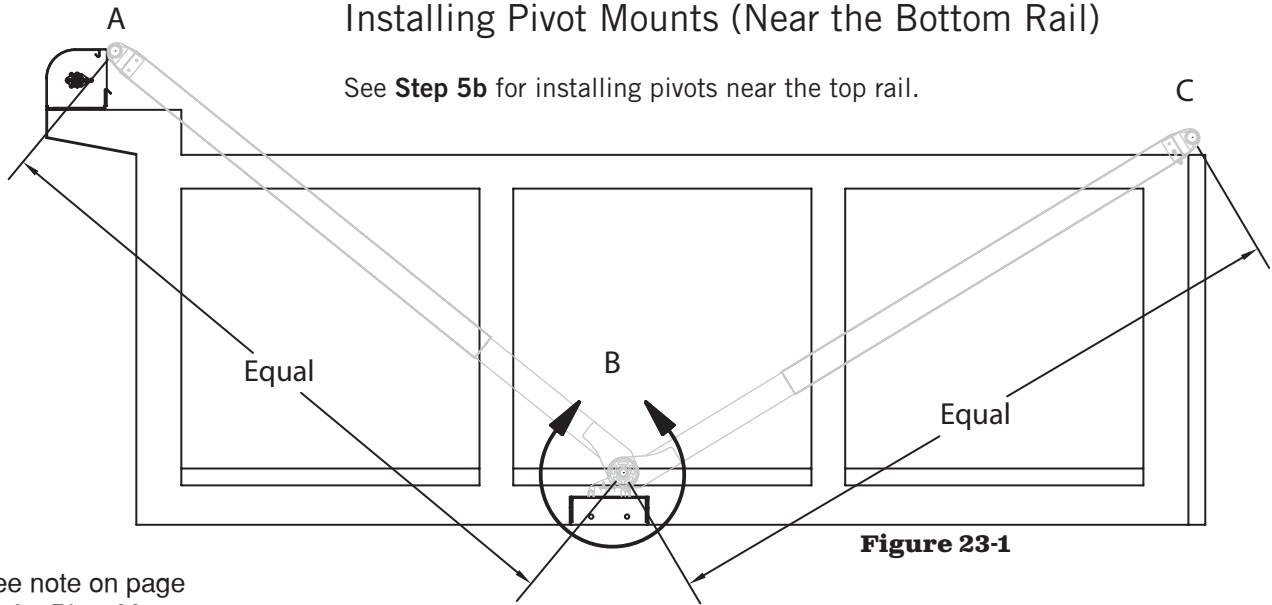


**Figure 22-2**

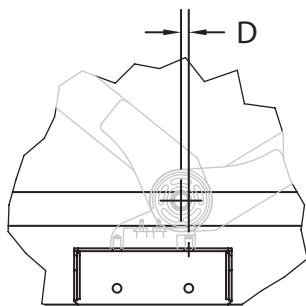
## Step 5a

### Installing Pivot Mounts (Near the Bottom Rail)

See **Step 5b** for installing pivots near the top rail.

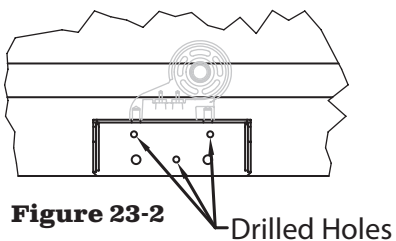


See note on page 22 for Pivot Mount drilling requirements.



DETAIL A

Pivot Size	D dimension
Small	1-1/16"
Medium	1-13/16"
Large	2-15/16"



**NOTE: Figure 23-1.** Note that the pivot assembly pivot point (B) is one point of a triangle. The other two points (A & C) are on top of the truck. The two downwards-pointing legs of the triangle must be the same length. These steps will make sure that the two legs are equal. The D dimension indicates the amount of offset from the center of the pivot mounting hole to the center of the pivot point. This will change with the different size of pivots. See chart for offset dimension.

- 1) Mark the rear edge of the tarp housing or the mounting plate in line with the tarp roll up bar on the driver's side and passenger's side. Mark these points and call them (A).
- 2) Determine where you want the rear of the tarp to be when it fully covers the box. Mark these points and call them (C).
- 3) **Figure 23-1.** Find a point at the side of the box that is the same distance from A and C. This is point B, where the spring assembly will be mounted. Mark this point on both sides.

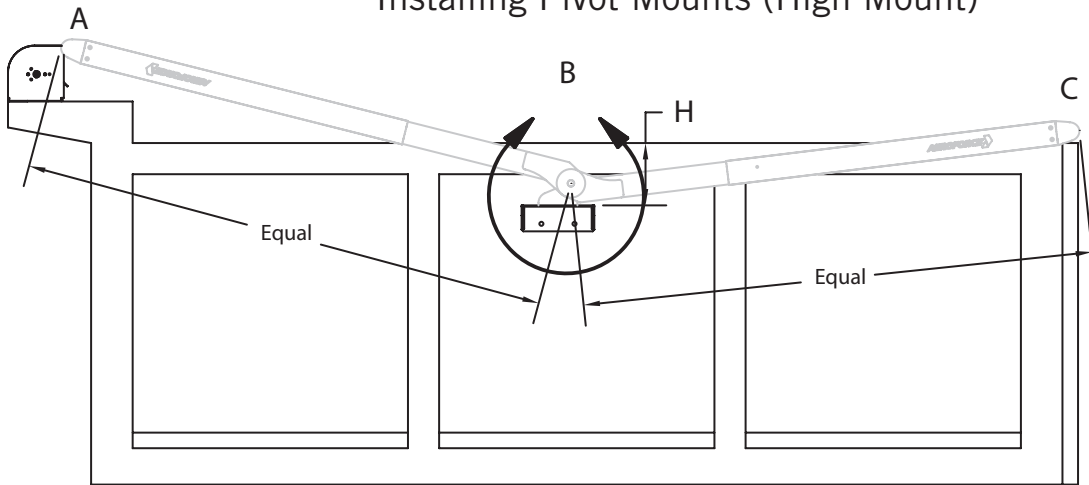
**NOTE:** The mounting brackets should be bolted to the dump body; if the trailer/truck body has an enclosed floor, then the mounting brackets can be welded in place.

- 4) Position the driver's side mounting bracket (1) to the point marked on the driver's side (B). Note the (D) offset dimension for your pivot size. Clamp the mounting bracket into position. The top of the mounting plate should be as high as possible from the bottom of the box.
- 5) **Figure 23-2.** Drill three 17/32" holes.
- 6) Bolt the pivot mount to the box or rail with 1/2-13 x 4 hex bolts (2), 1/2 flat washers (3), and 1/2-13 nylon hex nut (4).
- 7) Repeat **Steps 5a.4–5a.6** for passenger's side, then continue to page 25.



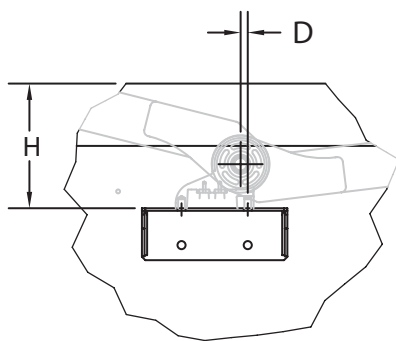
## Step 5b

### Installing Pivot Mounts (High Mount)

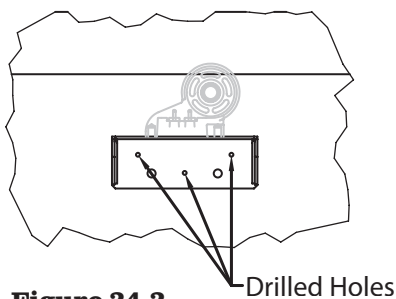


**NOTE:** Before you begin; to maximize spring tension, install pivots as low as possible on the dump body.

**Figure 24-1**



Pivot Size	D dimension
Small	1-1/16"
Medium	1-13/16"
Large	2-15/16"



**Figure 24-2**

Drilled Holes

**NOTE:** Figure 24-1. Note that the pivot assembly pivot point (B) is one point of a triangle. The other two points (A & C) are on top of the truck. The two downwards-pointing legs of the triangle must be the same length. These steps will make sure that the two legs are equal. The D dimension indicates the amount of offset from the center of the pivot mounting hole to the center of the pivot point. This will change with the different size of pivots. See chart for offset dimension.

**Important:** Dimension H must be a minimum of 12" for dump body up to 20' and a minimum of 24" for dump body from 21' to 25'.

**Important:** Any dump body length greater than 25', the mounting bracket must be mounted towards the bottom of the trailer.

- 1) Mark the rear edge of the tarp housing or the mounting plate in line with the tarp roll up bar on the driver's side and passenger's side. Mark these points and call them (A).
- 2) Determine where you want the rear of the tarp to be when it fully covers the box. Mark these points and call them (C).
- 3) **Figure 24-1.** Find a point at the side of the box that is the same distance from A and C. This is point B, where the spring assembly will be mounted. Mark this point on both sides.

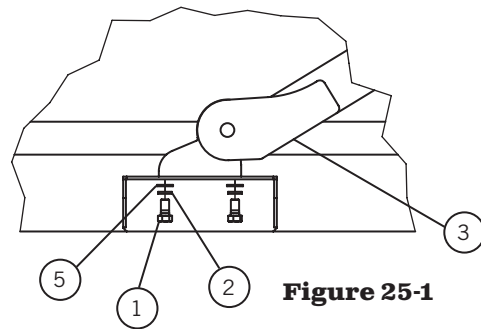
**NOTE:** The mounting brackets should be bolted to the dump body; if the trailer/truck body has an enclosed floor, then the mounting brackets can be welded in place.

- 4) Position the driver's side mounting bracket (1) to the point marked on the driver's side (B). Note the (D) offset dimension for your pivot size. Clamp the mounting bracket into position. The top of the mounting plate should be as high as possible from the bottom of the box.
- 5) **Figure 24-2.** Drill three 17/32" holes.
- 6) Bolt the pivot mount to the box or rail with 1/2-13 x 4 hex bolts (2), 1/2 flat washers (3), and 1/2-13 nylon hex nut (4).
- 7) Repeat **Steps 5b.4–5b.6** for passenger's side.



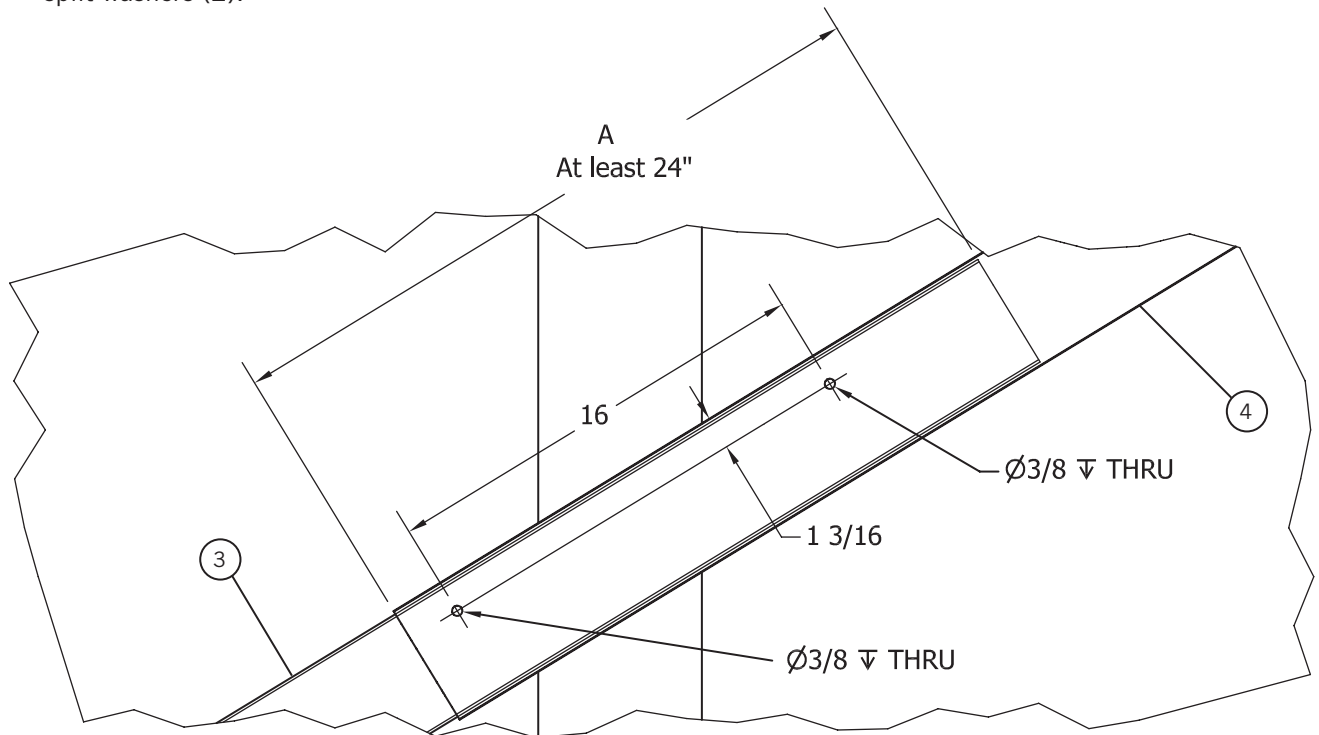
## Step 5 (cont.)

Index	Description	Qty
1	3/4-10 x 1-1/2 Bolt	2
2	3/4 Split Washer	4
3	Pivot Arm Assembly	1
4	Upper Arm	1
5	3/4 Flat Washer	2



**Figure 25-1**

8) **Figure 25-1.** Mount the Pivot Arm assembly (3) onto the mount using two 3/4" bolts (1) and split washers (2).



**Figure 25-2**

Dimension A needs to be at least 24".

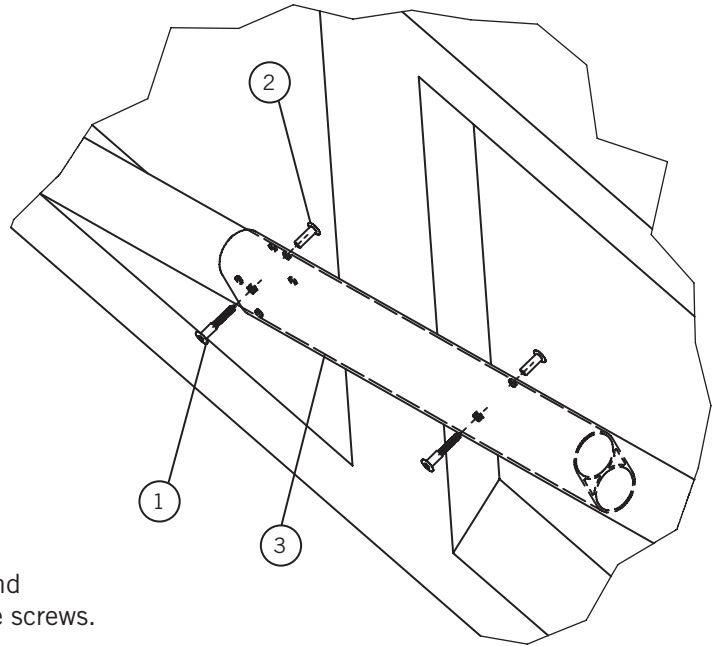
9a) **Figure 25-2.** Slide upper arm (4) over pivot arm assembly (3) until the total length of the arm, from the center of the pivot to the center of the 90 degree casting, is the same length as measured in **Step 5.3**. Make sure you have at least 24" overlap of the two arms.

9b) Drill two 3/8" holes through both arms. See above drawing for locations of the two holes.

**Important:** The arm shall never cover the safety labels located on the spring pivot assembly.

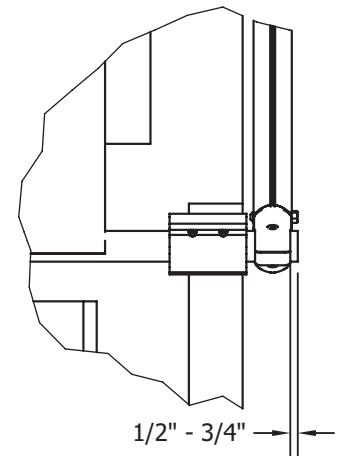
**Step 5** (cont.)

Index	Description	Qty
1	Binding Screws	2
2	Binding Barrels	2
3	Upper Arm	1
4	Cross Arm	1

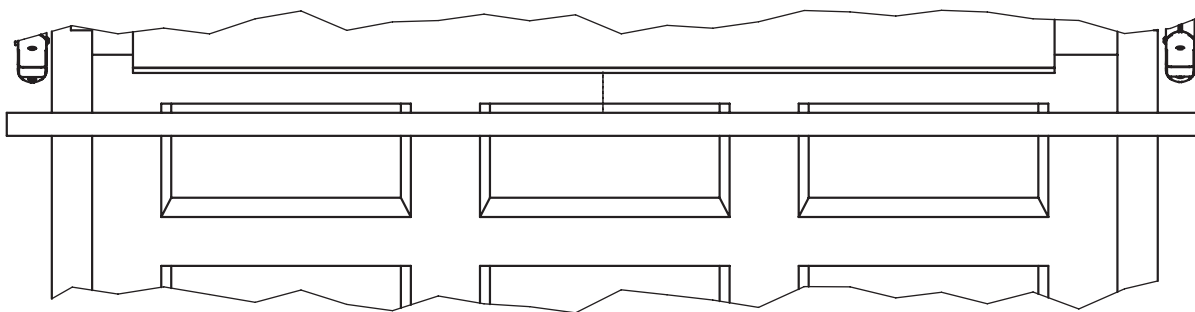


**Figure 26-1**

- 9c) **Figure 26-1.** Screw one binding screw (1) and barrel (2) in each hole. Use lock tight on the screws.
- 9d) Repeat **Steps 5.8–5.9c** for the other side of the truck.
- 10) **Figure 26-2.** Insert cross arm (2) through the pocket in the tarp (1) at the tailgate; center and place on the bed.
- 11) Insert 1/4-20 x 1 hex bolt (7) into each rubber bumper and attach 1/4-20 nylon hex jam nut (10).
- 12) Slide 2 rubber bumpers (5) onto each side of the cross arm (2).
- 13) Lift one swing arm and insert cross arm (2) into arm casting (4). Insert far enough so opposite swing arm can be lifted and inserted through the opposite arm casting (4).
- 14) **Figure 26-3.** Adjust cross arm (2) on one side to extend 1/2"-3/4" beyond arm casting (4).



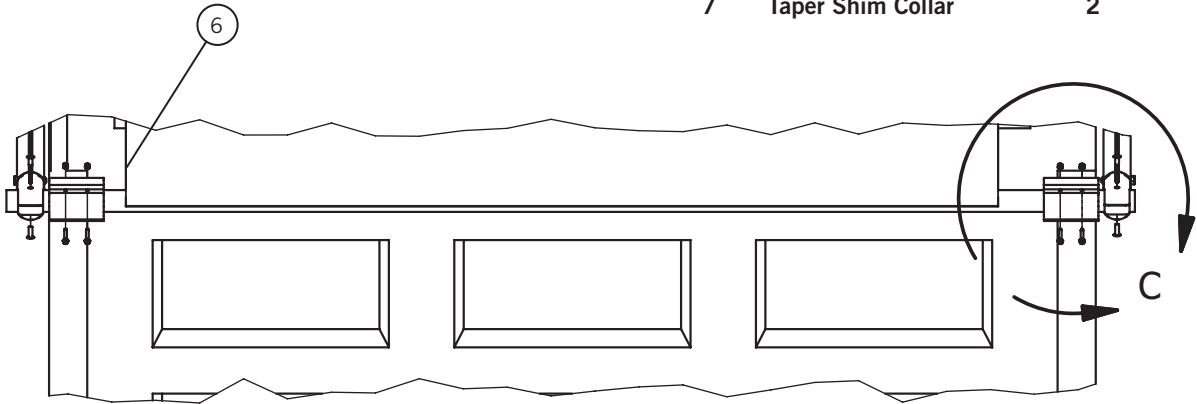
**Figure 26-3**



**Figure 26-2**

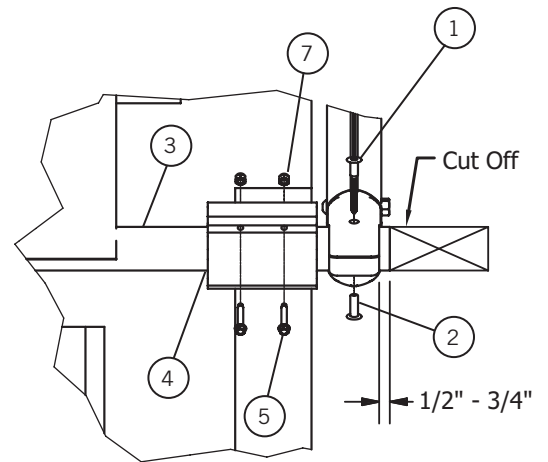
**Step 5** (cont.)

Index	Description	Qty
1	Binding Screws	2
2	Binding Barrels	2
3	Cross Arm	1
4	Cross Arm Bumpers	4
5	#14 x 1-1/2 Screw	4
6	Tarp	1
7	Taper Shim Collar	2



**Figure 27-1**

- 15) With the cross arm (2) resting on the tailgate, drill a 1/4" hole through the tube using the hole in the arm casting (4) as a guide. Secure with 3/8-16 x 3" hex bolt (9) and 3/8-16 nylon hex nut (11).
- 16) **Figure 27-1.** Position swing arm to be parallel with the bed. While maintaining that position, slide the opposite swing arm onto the cross arm (2) until it is parallel with the bed.
- 17) **Figure 27-2.** Cut excess cross arm (2) which extends 1/2"-3/4" beyond arm casting (4).
- 18) Insert plug ends (14) into each end of cross arm (2).
- 19) Position one set of rubber bumpers (5) to sit on tailgate and one set to hit end plates of the tarp housing, then tighten bolts.



**Figure 27-2**

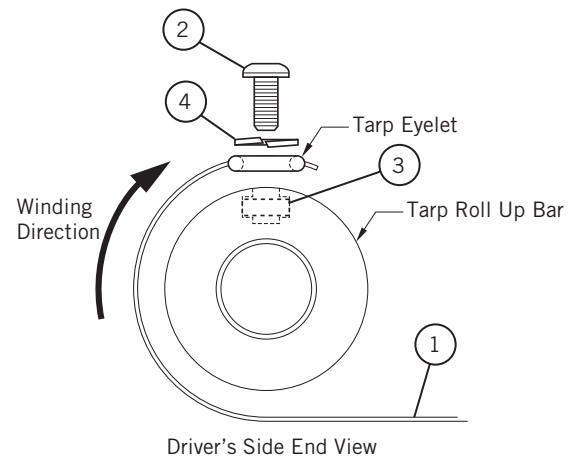
## Step 6a

### Installing Tarp to Roll Up Bar, Roll Under (Standard)

**NOTE:** Hardware taped to roll bar

Index	Description	Qty	Index	Description	Qty
1	Tarp	1	3	1/4 Square Nut	6
2	1/4-20 x 1/2 Pan Head	6	4	1/4 Split Lock Washer	6

- 1) Figure 28-1.** Pull the loose end of the tarp (1) under the roll up bar, winding from the underside. Make sure the tarp is centered from side to side.
- 2)** Mark the tarp roll up bar for fastener placement using the grommets in the tarp as a guide.
- 3)** Secure tarp (1) with 1/4-20 pan head Phillips (2), 1/4-20 square nuts (3), and 1/4 split lock washers (4).



**Figure 28-1**

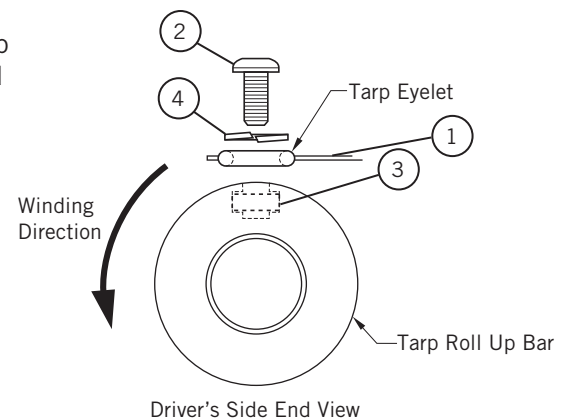
## Step 6b

### Installing Tarp to Roll Up Bar, Roll Over (Optional)

**NOTE:** Hardware taped to roll bar

Index	Description	Qty	Index	Description	Qty
1	Tarp	1	3	1/4 Square Nut	6
2	1/4 Pan Head	6	4	1/4 Split Lock Washer	6

- 1) Figure 28-2.** Pull the loose end of the tarp (1) over the roll up bar, winding from the topside. Make sure the tarp is centered from side to side.
- 2)** Mark the tarp roll up bar for fastener placement using the grommets in the tarp as a guide.
- 3)** Secure tarp (1) with 1/4-20 pan head Phillips (2), 1/4-20 square nuts (3), and 1/4 split lock washers (4).



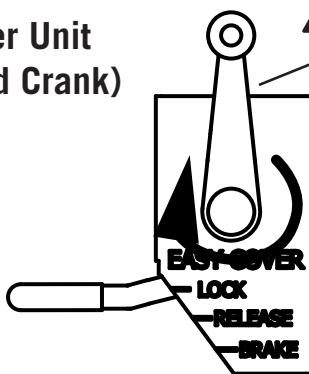
**Figure 28-2**

## AeroForce F2B Manual Model

**CAUTION** Crank handle is only used for uncovering. Remove and store crank handle when not in use.

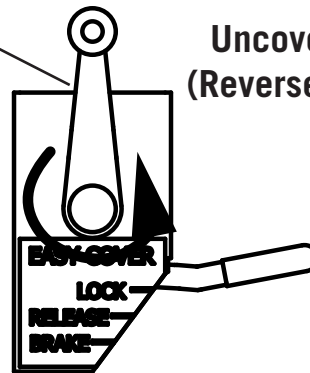
**NOTICE** Face vehicle into the wind during operation. Wind may cause tarp to sail and damage system.

### Uncover Unit (Standard Crank)



**CAUTION** Crank handle is only used for uncovering. Remove and store crank handle when not in use.

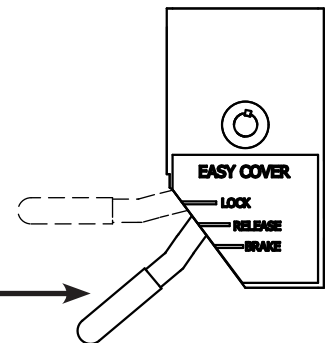
### Uncover Unit (Reverse Crank)



### Cover Unit

**NOTICE** Keep brake handle engaged to provide braking action while releasing (covering) the tarp. If handle is released too soon while covering, damage may occur.









Pull brake handle down quickly to brake position



## Maintenance Recommendations

**Aero Industries recommends a weekly inspection of the following items:**

**IMPORTANT:** Replace all worn or broken parts immediately. Repairs must **ONLY** be made after proper instruction.

-  Inspect Tarp for wear and tears.
-  Inspect Arms for damage (cracked, dented or bent).
-  **Bearings:** Pull the shafts from side to side and in and out. If there is excessive play, replace the bearings. Apply penetrating oil lightly as needed.
-  **Springs:** Examine springs for breakage or distortion. Apply a light coat of penetrating oil to tension springs as needed.
-  **Fasteners:** Make sure all mounting bolts and nuts are in place and tight and that no parts are worn or damaged.
-  **Chain:** Check the chain tension, that links move smoothly, and make sure the master link is on. Lubricate the chain regularly with penetrating oil.
-  **Electrical Connections:** Check all electrical connections and tighten any that have become loose.
-  **Safety Labels:** Clean labels with soap and water. Replace if damaged and/or difficult to read.

Replacement Parts and instructions may be obtained from your Aero dealer or by contacting Aero Industries.



Call 1-800-535-9545  
[www.aeroindustries.com](http://www.aeroindustries.com)

**INDIANAPOLIS, IN**  
Indianapolis, IN 46241  
800-535-9545  
FAX: 317-244-1311

**OMAHA, NE**  
Omaha, NE 68137  
800-535-9545  
FAX: 402-895-6129

**KENT, OH**  
Kent, OH 44240  
888-237-2262  
FAX: 330-626-3277

**VALLEY, NE**  
Valley, NE 68064  
800-535-9545  
FAX: 402-895-6129

© 2023 Aero Industries, Inc.

Aero, , and AeroForce are registered trademarks of Aero Industries. All rights reserved.

US: 10023033, 10703180 B2, 9073416

Canada: 2996297, 2775212